

Shorter contribution

A Portable Automatic Weather Station: description and operation

Introduction

The Bureau of Meteorology Research Centre (BMRC) in collaboration with the Northern Territory Regional Office of the Bureau of Meteorology (BoM) has developed a low-cost high quality Portable Automatic Weather Station (PAWS) for use in a variety of mesoscale meteorology research programs. The purpose of this note is to describe PAWS and present results of some intercomparison tests which give an indication of its overall performance. Both laboratory and field based tests are discussed.

PAWS is a self contained unit that can be installed quickly by one person and operate unattended in remote locations for long periods of time. Temperature, humidity, pressure, wind speed, wind direction and rainfall are recorded on site and if required can be interrogated remotely using a packet radio Ultra High Frequency (UHF) communication system. Temperature and humidity sensors (Vaisala HMP-133Y HUMICAP) are housed in an aspirated radiation shield mounted 1.2 m above ground level (AGL); the pressure transducer (Setra 270) is interfaced to a horizontally oriented static head (to minimise wind induced dynamic pressure effects); the wind sensors (VDO) are sited 10 m AGL on top of a guyed telescopic tower and a standard 210 mm diameter tipping bucket rain-gauge is employed for rainfall measurements. More sensor details are provided in Table 1. Solar panels provide charging of the battery power supply. Including the commercially available sensors the total cost of the system is estimated to be \$12,000.

A primary part of the PAWS data system is a programmable Unidata 6004-B portable data logger containing an 8 bit 80C31 microprocessor running at 14.7456 MHz. The unit has 128K of battery backed CMOS RAM with optional use of a PCMCIA/JEIDA 256K 2.0 68 pin standard 256K-16 MB memory card. An RS232 logger port is connected to a JED processor within the radio module. The JED processor interrogates the logger every minute to extract one-minute average data. The JED processor translates the logger hexadecimal binary data to a text message sent via an RS232 connection to a Kantronics KPC-3 modem.

Intercomparison studies

Of course the accuracy of the measurements under field conditions is dependent upon many things including siting, instrument exposure to radiation, precipitation occurrence etc. as discussed by Brock et al. (1995). At a typical irradiance of 1080 W m^{-2} , when wind speeds are less than 0.5 m s^{-1} , radiation-induced temperature errors can reach more than 2°C in an un aspirated shield. Hence for PAWS the temperature/humidity sensor was mounted in an in-house developed aspirated radiation shield shown in Fig.1. It consists of three vertically oriented concentric cylindrical shields. Aspiration is achieved by a fan mounted on the top of the unit drawing a 3 m s^{-1} airflow vertically past the shielded temperature and humidity sensors.

During the development of PAWS a series of laboratory and environmental intercomparison studies was undertaken to assess its system performance, primarily in tropical locations. Some of these comparisons are now presented. For the temperature measurements PAWS was evaluated in the field against:

1. The commercially available Teledyne Geotech 327C. This unit consists of a series of aspirated baffles and shields to protect an inner cavity surrounded by thin cylindrical shields. McTaggart-Cowan and McKay

Fig. 1 Schematic of the PAWS aspirated radiation shield.

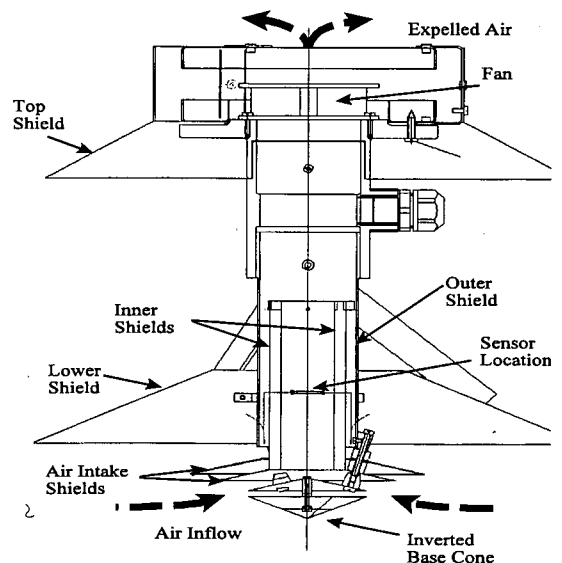

Corresponding author address: Dr T. Keenan, Bureau of Meteorology Research Centre, GPO Box 1289K, Melbourne, Vic. 3001, Australia.

Table 1 Summary of PAWS instrument ranges and accuracy.

<i>Sensor</i>	<i>Range</i>	<i>Accuracy</i>	<i>Height</i>	<i>Sensor</i>
Wind speed	0-35 ms ⁻¹	±0.5 m s ⁻¹	10 m	VDO
Wind direction	0-360°	±1.0°	10 m	VDO
Air pressure	800-1100 hPa	±0.15 hPa	1.0 m	Setra 270
Air temperature	-20-80°C	±0.2°C	1.2 m	HMP 133Y
Relative humidity	0-100 %	±2 %	1.2 m	HMP 133Y
Rainfall	0.2 mm	5 %	0.1 m	Rimco Bucket

(1977) found it had a small sensitivity (0.00027°C per W m⁻² or ~0.2°C) to net solar radiation under typical tropical conditions. For the following experiments the Teledyne thermistor was replaced by a substantially smaller 90 mm long and 2.5 mm wide cylindrical Class A RTD. This platinum resistance device is quoted to be accurate to within ±0.15°C.

2. A Micromac (BoM naturally ventilated Stevenson screen with Class A platinum wet and dry bulb elements) system. The latter offered the opportunity to compare PAWS with a standard un aspirated BoM automatic weather station.

The following intercomparisons were conducted in undisturbed conditions (no rainfall) at Darwin Airport during seven days of July 95. The results are quite typical (different periods produce almost identical results).

Figure 2(a) indicates the characteristic diurnal behaviour in the observed temperature (based on one-minute averages) deviation between the Teledyne and PAWS (Micromac). The mean Teledyne temperature (solid line) is also shown along with a curve (dashed) depicting the mean deviation averaged over successive 20-minute periods. The mean of the observed temperature differences between PAWS and the Teledyne (Fig. 2(a)) is 0.09°C. There is a diurnal trend with a peak mean deviation of ~0.3°C during the mid-afternoon i.e. the Teledyne indicates slightly warmer daytime temperatures than PAWS. However these differences are small. Ninety percent of daytime (0900-1700 CST) PAWS-Teledyne temperature deviations are less than 0.5°C. At night, the differences are extremely small. These results are consistent with those of Moore and Callander (1987) who found the Teledyne unit was ~0.2°C warmer in the mid-afternoon than their aspirated 'Vector' unit.

Larger temperature differences are evident in the Teledyne-Micromac comparison shown in Fig. 2(b). In this case, contrary to expectations, the unventilated Micromac is on average 0.1°C cooler than the Teledyne with a peak mean deviation of almost -0.5°C

during the mid-afternoon. The standard deviation of the temperature differences is almost two times larger than obtained during the PAWS-Teledyne intercomparison. In this case, positive temperature differences up to 1.5°C were observed during the day and, surprisingly, the temperature deviations did not seem to be related in any systematic way to wind speed (not shown).

Observed differences in temperature can result not only from variations in the radiation shield configuration but also from sensor differences. The impact of the latter is further explored in Fig. 2(c), where an RTD platinum resistance device 'identical' to that employed in the Teledyne replaced the Vaisala HMP 133Y sensor within PAWS. The results are very similar to those observed with PAWS employing a Vaisala sensor. The conclusion is that the Vaisala sensor located in the PAWS housing contributes very little to the observed temperature differences.

To assess the accuracy of the PAWS humidity measurements, laboratory-based and manufacturer-specified salt bath calibration procedures were first employed to pre-check PAWS humidity estimates. Field performance was then investigated using the previous methodology. One-minute averages of relative humidity sensed by PAWS and the Micromac are shown in Fig. 3 for this case. A less well-defined diurnal cycle is apparent in the PAWS-Micromac relative humidities. During the pre-dawn period, there is considerable scatter in the range ±2 per cent up to about 0800 CST. After that time the PAWS relative humidities tend to be three per cent higher than the Micromac values although the differences decrease during the day. This may be related to increased wind speed during the day producing more effective aspiration of the Micromac.

The performance of the PAWS VDO wind sensor in the PAWS tower configuration has been investigated in a series of wind tunnel tests undertaken within the Royal Melbourne Institute of Technology Faculty of Engineering wind tunnel and in the field with a series of intercomparisons with a co-located Synchrotac wind

Fig. 2 Scatter diagram showing diurnal cycle in temperature differences (one-minute averages) between various AWS configurations. The aspirated Teledyne is the reference. (a) Teledyne-PAWS (aspirated), (b) Teledyne-Micromac (Wooden louvered un aspirated Stevenson screen), (c) Teledyne-PAWS (employing identical RTD temperature sensors). Mean (ΔT) and standard deviation (σ_T) of differences are indicated in the top left corner. The solid line is the average Teledyne temperature and the dashed line is the mean difference between the respective units (successive 20-minute averages).

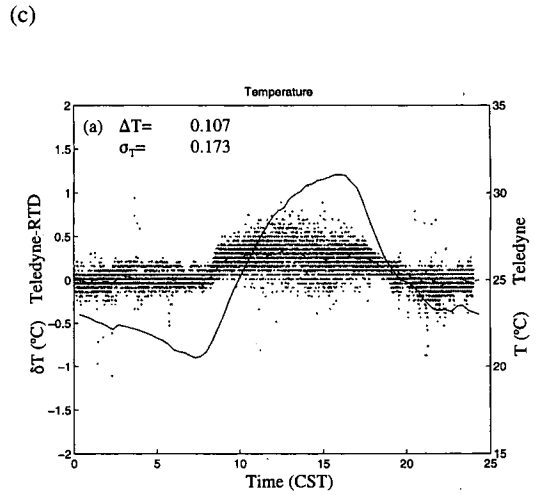
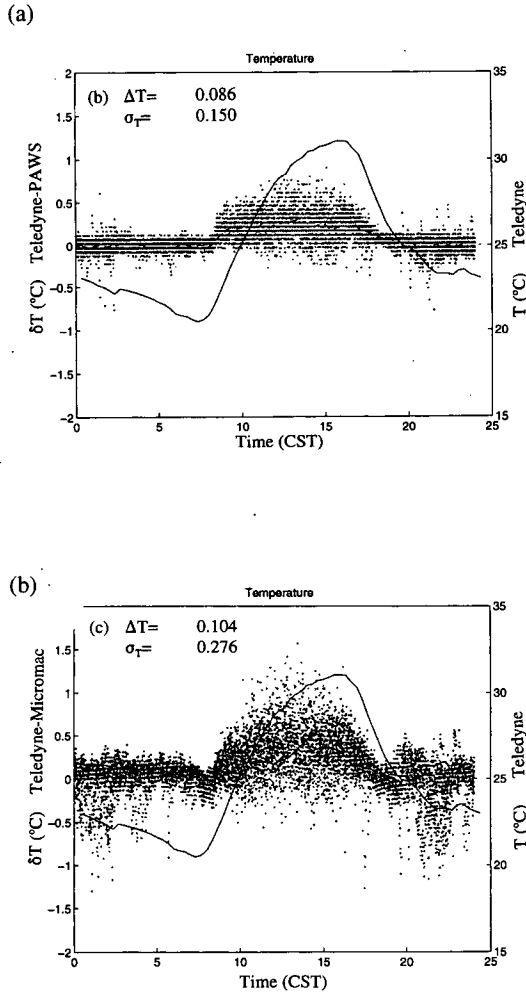

Fig. 3 Scatter diagram showing diurnal cycle in relative humidity deviations between PAWS (Vaisala HMP 133) and Micromac unit (Wooden louvered Stevenson screen as housing). Mean (ΔRH) and standard deviation (σ_{RH}) of differences are indicated in the top left corner. The solid line is the average PAWS relative humidity and the dashed line the mean of the PAWS-Micromac differences (successive 20-minute averages).

sensor. In the wind tunnel a series of ‘wind ramp’ tests were undertaken by increasing the tunnel flow* from 2.5 m s⁻¹ to 30 m s⁻¹ nominally in increments of 2.5 m s⁻¹.

* The uncertainty in tunnel flow is estimated to be ± 0.5 m s⁻¹ at speeds less than 1 m s⁻¹ and $\pm 1\%$ for speeds between 3 and 30 m s⁻¹.

Overall the performance of the VDO was generally consistent with the manufacturer’s claims, at least for wind speeds below about 15 m s⁻¹.

The PAWS tower (on which the VDO is mounted) is a potential source of flow distortion and wake effects which can potentially result in erroneous wind measurements. Ideally, the VDO should be directed into

the oncoming flow and located at least four times the tower diameter from the tower. The latter is certainly achieved, however, the sensor is not always in the upstream flow and so the effect of flow distortion on the estimated wind speeds was tested by rotating the alignment of the PAWS wind boom through 360° relative to the axis of the wind tunnel flow. Results are shown in Fig. 4 for tunnel flow speeds of 7.5 and 17 m s⁻¹ (since flow distortion is potentially a function of Reynolds number). An almost ten per cent decrease in the PAWS wind speed is evident where the VDO instrument boom is located directly downstream of the tower i.e. where $\alpha = 180^\circ$ in Fig. 4. For almost all other flow directions no significant flow distortion or blockage effects are evident.

Under field conditions good agreement was achieved between a PAWS and Synchronac unit co-located at Darwin Airport. The mean difference in the zonal (meridional) wind was -0.025 m s⁻¹ (-0.036 m s⁻¹). A number of non-zero PAWS wind speeds corresponding to zero velocity for the Synchronac are evident in both the u and v data. This is thought to be associated with a higher starting threshold with the heavier Synchronac unit.

The accuracy of the atmospheric pressure measurement depends in part upon the performance of the static pressure head. Turbulence can induce varying angles of attack and induce dynamic pressure fluctuations larger than the variations in the static pressure. The issues are discussed in detail by Nishiyama and

Bedard (1991). The dynamic pressure fluctuation (p_d) is given by:

$$p_d = \rho/2 U_p^2$$

where ρ is the air density and U_p is the wind variation. In this case the effect of turbulence was simulated by undertaking PAWS pressure measurements in the wind tunnel as a function of flow speed with the static head tilted at angles (β) of 0 and 25° to the horizontal. The results are shown in Fig. 5 along with those deduced from the equation (for $\beta=25^\circ$). At $\beta=25^\circ$ significant pressure variations are induced. For example, a 15 m s⁻¹ gust with a tilt angle of 25° induces a 0.2 mb increase in pressure. The PAWS pressure measurements are not independent of wind speed. With the static head aligned horizontally the standard deviation of the VDO pressure measurements was ~0.04 hPa for wind speeds in the range 2.5-30 m s⁻¹. This places a limit on the accuracy of the pressure measurements. The results suggest that further work is necessary to improve the PAWS static head design. Nishiyama and Bedard (1991) show that a quad head device significantly reduces the wind-induced dynamic pressure fluctuations, at least compared with a single plate design of the type employed by PAWS.

In the field, small pressure differences are evident in comparing PAWS and a Micromac unit employing a Vaisala DPA 25 device. The mean pressure difference was 0.003 hPa with the 95 percentile range extending from -0.08 to 0.1 hPa.

Fig 4 Relative difference (percent) between wind tunnel and PAWS measured wind speeds as a function of flow speed and direction (relative to α).

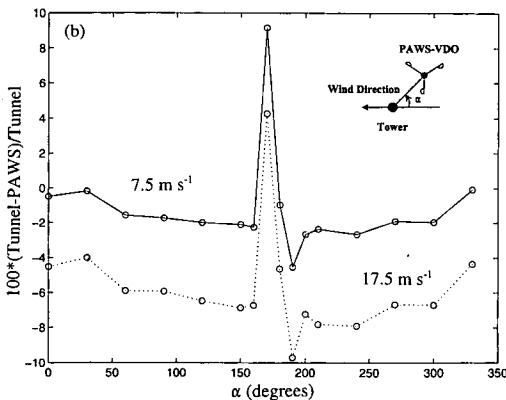
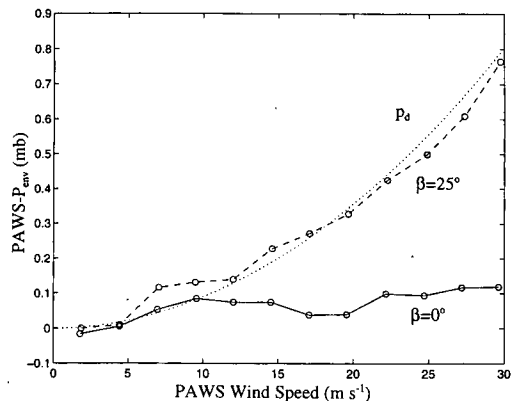

Fig 5 Difference between PAWS and environmental pressure as a function of wind tunnel flow speed and inclination angle (β) of the static head relative to the horizontal. Theoretical increase in dynamic pressure from the equation above (.....) is indicated.



Some on-going quality control procedures

For diagnostic evaluation of the PAWS data a software package has been developed for use on-site (microcomputer-based) in the field and at a central site (UNIX workstation based) where all PAWS data are available. This package employs IDL software to produce user specified time series and histogram analyses of PAWS data including derived thermodynamic variables such as equivalent potential temperature etc. Station variables can be treated separately and/or displayed in combination for easy intercomparison and 'buddy checking' in real time. The aim is to quickly detect any significant faults in the data, including outliers, biases etc. so that remedial action can be implemented as soon as possible. A menu driven user interface enables easy access to the software. The package is configured identically on both the workstation and microcomputer platforms although the workstation enables a complete real-time mesoscale analysis of PAWS mesonet data following the approach of Glowacki et al. (1995). This latter feature is also particularly useful for diagnosing the performance of individual PAWS.

Conclusions

A brief description of PAWS has been provided. The results show that small differences exist between humidity and temperature measurements obtained with other systems. However the PAWS temperatures are almost identical to those of the Teledyne and other quality aspirated psychrometers (results not presented herein, refer to Keenan et al. (1998)). The cooler daytime temperatures and increased variability associated with the 'more standard' Micromac (at least compared to the PAWS and other units) are thought to be associated with an overall slower thermal response. The observed differences are not a function of wind speed and so aspiration by itself is not the primary problem (a lack of aspiration during daytime would result in a temperature excess rather than a deficit). Instead it is thought that the Micromac is not sensing the extremities of warm turbulent fluctuations associated with day time positive heat fluxes. In any case, the results indicate that the differences are small.

Some potential problems exist with the PAWS wind and pressure estimates. Blockage by the tower is a potential problem for flow along the anemometer boom axis and the simple static head configuration employed by PAWS is not immune from wind effects. Further work is necessary to optimise this aspect of PAWS. The 'quad head' design of Nishiyama and Bedard (1991) appears to be a suitable alternative.

The results demonstrate that PAWS provides quality meteorological observations that are certainly equivalent in accuracy to presently employed operational systems. The latter is important given the 'mix' of observational systems that are often necessary in research and on-going operational applications. In the latter context a PAWS mesonet has been operating in support of operational forecasting within the Northern Territory.

T. Keenan and V. Kondratiev

Bureau of Meteorology Research Centre, Melbourne

G. Buis and R. Christmas

Regional Office, Bureau of Meteorology, Darwin

References

- Brock, F.V., Richardson, S.J. and Semmer, S. 1995. Passive Multiple Solar Radiation Shields, *Proc. 9th Symposium on Met. Obs. and Instr.*, Amer. Met. Soc., Charlotte, NC, March 27-31, 329-334.
- McTaggart-Cowan, J.D. and McKay, D.J. 1977. An intercomparison of radiation shields for auto stations. WMO Tech. Conf. On Instrumentation and Methods of Observation, *WMO No 480*, 27-30 July 1977, Hamburg.
- Glowacki, T., Keenan, T., Whimpey, M. and May, P. 1995. Determination of the mesoscale boundary layer flow using multiple source data and statistical interpolation. *Australian Physical and Oceanography and Australian Meteorological and Oceanographic Society, Joint Conference Abstracts*, Lorne, Victoria.
- Keenan, T.D., Kondratiev, V., Buis, G. and Christmas, R. 1998. The Bureau of Meteorology Research Centre Portable Automatic Weather Station. *BMRC Research Report No. 68*, pp30.
- Moore, D.M. and Callander, B.A. 1987. A portable aspirated thermometer for air temperature measurement, *Met. 0.14. Boundary layer Research Turbulence and Diffusion Note, TDN 188*, British Meteorological Office, Bracknell, Berks, UK, 33pp.
- Nishiyama, R.T. and Bedard, A.J. 1991. A 'Quad-Disc' static pressure probe for measurement in adverse atmospheres: With a comparative review of static head pressure probe designs. *Rev. Sci. Instrum.*, 62, 2192-204.

