

MTSAT HiRID

Technical Information

Issue 3
1 June 1999

Japan Meteorological Agency
1-3-4 Otemachi, Chiyoda-ku, Tokyo, Japan, 100-8122

DOCUMENT CONTROL

Issue	Date	Status and Change
-------	------	-------------------

Issue 1	1 March 1998	Original Issue
---------	--------------	----------------

Issue 2	1 July 1998	
---------	-------------	--

APPENDIX A (1 – 7)

- 1) Section 2.2.1 Documentation Sector
- 2) Section 2.2.2 Infrared Image Data Sectors
- 3) Table A.1 S/C & CDAS documentation block (Word No.1)
- 4) Table A.1 S/C & CDAS documentation block (Word No. 98)
- 5) Table A.4 Orbit and attitude data block (Word Nos. 2957-2962)
- 6) Table A.4 Orbit and attitude data block (Word Nos. 2977-2982)
- 7) Table A.7 Calibration data block (Word Nos. 5-10)

APPENDIX B

<u>Issue 3</u>	<u>1 June 1999</u>	
----------------	--------------------	--

APPENDIX A (1 – 4)

- 1) Section 1. Main characteristics
- 2) Table A.1 S/C & CDAS documentation block (Word No. 65)
- 3) Table A.1 S/C & CDAS documentation block (Word No. 68)
- 4) Table A.6 Contents of orbit prediction data sub-block (Word Nos. 195-200)

APPENDIX B (One line of Page 9)

Amended or supplemented parts are underlined.

Reformatted by mdk 8/99

CONTENTS

1. Introduction
2. Outline of HiRID
3. Transmission of HiRID
4. Data format of HiRID
 - 4.1 Change of dissemination timing of data
 - 4.2 Change of image data frame
 - 4.3 Addition of 3.7 μ m IR channel data (IR 4)
 - 4.4 Increase of quantization level
 - 4.5 Change of navigation information
 - 4.6 Change of calibration information

APPENDIX A : Characteristics of MTSAT HiRID

APPENDIX B : Sample Program of MTSAT HiRID and GMS-5 S-VISSR image navigation

APPENDIX C : Processing of expanded infrared data with a sample program

1. Introduction

Japan Meteorological Agency (JMA) is now developing the Multi-functional Transport Satellite (MTSAT), which is planned to be operational on the geostationary orbit at 140°E in March 2000 following its launch in September 1999 as the successor to GMS-5.

Digital image data for Medium-scale Data Utilization Stations (MDUS) are named the High Resolution Image Data (HiRID) and will be disseminated via MTSAT in place of Stretched Visible Infrared Spin Scan Radiometer data (S-VISSR) of GMS-5. The data transmission method and data format of HiRID will be different from those of S-VISSR. The MTSAT will introduce a new transmission and earth observation systems. The HiRID format is designed to be upper-compatible with S-VISSR format.

This document is prepared to provide MDUS users with the necessary information on data reception and data processing of HiRID for MDUS users. The outline of HiRID and the main alterations from S-VISSR are described in Chapter 2, the transmission method in Chapter 3 and the HiRID data format in Chapter 4. The specification of HiRID is shown in **APPENDIX A**. A sample program of image navigation for HiRID and S-VISSR is shown in **APPENDIX B**. This program is the same as that for S-VISSR which is used currently. The processing of expanded infrared data with a sample program is also shown in **APPENDIX C**.

2. Outline of HiRID

This chapter describes the differences on the data transmission and processing of between HiRID and S-VISSR.

MTSAT is equipped with two transmitters which transmit Imager observation data and HiRID dissemination data separately. The carrier wave to transmit HiRID is not interrupted even when Imager observation data are being transmitted. If a receiving system of MDUS utilizes the carrier interruption to receive S-VISSR, it may need to be modified due to the transition to HiRID. Details of data transmission are explained in Chapter 3.

MTSAT is newly equipped with an infrared sensor of 3.7 μm band (IR 4) in addition to the infrared sensors (IR 1-3) and visible sensors (VIS) of GMS-5. The observation data with all the sensors is disseminated by HiRID. Data in all infrared channels (IR 1-4) of MTSAT has 1024 (10-bit) quantization levels which is increased from 256 (8-bit) levels of GMS-5. Image-processing programs in the current MDUS need to be modified in order to use these new data. The format of the upper 8-bit data of IR 1-3 and visible (VIS) data of MTSAT are same as S-VISSR data. Therefore image-processing programs in the current MDUS can be used without modifications to obtain HiRID data with the same bit depth as S-VISSR.

Navigation data included in HiRID is updated during the course of observation by processing its image data at the ground station of JMA. Fixed conversion tables from brightness levels to physical quantities are used in HiRID, because calibration is made to Imager observation data at the ground station of JMA before it is disseminated as HiRID. Details of data format and processing are explained in Chapter 4.

3. Transmission of HiRID

Raw data of earth observation obtained with MTSAT and GMS are called “Imager observation data” and “VISSR observation data”, respectively. MTSAT is equipped with two transmitters which transmit Imager observation data and HiRID dissemination data separately, while in the case of GMS VISSR observation data and S-VISSR are transmitted from one transmitter.

As shown in **Figure A**, one-line data of VISSR observation and S-VISSR are transmitted alternately within the period of 600 milliseconds, which corresponds to one spin of GMS-5. Therefore, the carrier wave of S-VISSR is interrupted for approximately 50 milliseconds while VISSR observation data are transmitted.

As shown in **Figure B**, the transmission of carrier wave of HiRID is not interrupted, because Imager observation data and HiRID are transmitted separately.

If an MDUS receiving system utilizes the interruption of carrier wave to detect the end of each line data, the MDUS needs to be modified so that it can detect the end of line without using the interruption and can reset PN sequence at this timing. HiRID data stream is shown in **Figure C**.

4. Data format of HiRID

4.1 Change of dissemination timing of data

HiRID is composed of the dummy data part and the significant image data part as shown in **Figure 1**. The significant image data part consists of 2201 lines of data. During the transmission of the significant data part, the frame flag in Documentation sector is ON. Dummy data, in which the frame flag is OFF, is sent before and after the significant image data of HiRID. While dissemination of S-VISSR starts almost simultaneously with VISSR observation, significant image data of HiRID are disseminated with a delay of about 5 minutes from the start of Imager observation as shown in **Figure 2**. Dissemination time of significant image data of HiRID is approximately 22 minutes for the full disk observation and is approximately 11 minutes for the hemisphere observation.

4.2 Change of image data frame

Figure 3 shows the image data frame of S-VISSR and HiRID. The number of lines from north to south in the full disk observation is 2201 which is less than that of S-VISSR data. The number of pixels from west to east on IR image is 2291 which is the same as that of S-VISSR data.

4.3 Addition of 3.7 μm IR channel data (IR 4)

The 3.7 μm channel (IR 4) sensor is newly carried on MTSAT. IR 4 data is included in HiRID in addition to the visible (VIS), split window (IR 1, IR 2) and water vapor (IR 3) data.

Band width of these sensors are as follows:

VIS	0.55 - 0.80 μm
IR1	10.3 - 11.3 μm
IR2	11.5 - 12.5 μm
IR3	6.5 - 7.0 μm
IR4	3.5 - 4.0 μm

As shown in **Figure 4**, IR 4 data are stored in the third IR image of HiRID format sectors as 10 bit data. In order to use the IR 4 data, image-processing program of the current MDUS needs to be modified so that the second IR image data sectors are processed.

4.4 Increase of quantization level

The quantization of VIS data of HiRID remains to be 6 bits. In the case of IR data, the quantization is refined to 10bits or 1024 levels from 8 bits or 256 levels in S-VISSR. IR 1-3 data are divided into the upper 8-bit part and the lower 2-bit part. The former is called Most Significant Bits (MSB) and the latter Least Significant Bits (LSB).

As shown in **Figure 4**, in HiRID the upper 8-bit data of IR 1-3 are placed in the same areas and in the same format as S-VISSR, and the lower 2-bit data is put into the spare area which is filled with dummy data in S-VISSR format. Therefore, users have to combine the upper 8-bit data with the lower 2-bit data to process HiRID as 10 bit image data.

4.5 Change of navigation information

The processing of navigation is necessary for MDUS users so that each pixel/line of image data is assigned correctly to the corresponding latitude/longitude of the earth. The navigation data is stored in the Simplified mapping block and the Orbit and attitude data block (S & O data blocks) in Documentation sector. As shown in **Figure 5**, 200 lines of S & O data blocks are used to send one set of navigation data and is Sub-commutation ID is used to identify each of the 200 lines.

Navigation data of S & O data blocks in HiRID is updated during the course of the observation. At the start of dissemination, the predicted navigation data based on the previous observations are given in the S & O data blocks. As some errors are anticipated in the predicted data, navigation data are updated based on the current observation and they are put into S & O data blocks.

Figure 6 explains the update timings of navigation data in the full disk observation. For the first 800 lines (1 - 800), the predicted navigation values are used. For the next 1200 lines (801 - 2000), the corrected navigation data, which is determined by real time processing, are given. For the lines from the 2001st line, the navigation data are corrected again. In the case of the hemisphere observation, updating is done only once at the line of 801. The flag that indicates updating is newly set as the 99th byte of Spacecraft (S/C) and CDAS documentation block (Table A.1).

4.6 Change of calibration information

Calibration tables for IR of S-VISSR are updated for every observation. On the other hand, fixed calibration tables are used in HiRID. Imager observations with MTSAT are performed using two detectors of each IR channel and eight detectors of VIS channel. In order to correct the difference of characteristics in detectors, calibration is performed for every channel data as described below. At first, brightness levels of observed data are converted into physical values using conversion coefficients which take the difference in detectors into consideration. The derived physical value is assigned again to a brightness level using the fixed conversion table (temperature level in IR and albedo level in VIS). MDUS users can use HiRID as the calibrated image data without paying attention to the difference in the characteristics of detectors and can obtain physical values with the fixed conversion tables. There are five conversion tables for four IR channels and one VIS channel. HiRID has three conversion tables for 8-bit data of IR1-3 and one conversion table for 6-bit data of VIS in the Calibration block. The conversion table for IR4 is not stored in HiRID. Besides dissemination of the conversion tables by HiRID, JMA will announce and distribute all the following conversion tables when their values are determined.

- conversion tables for IR 10-bit data of IR1- IR4
- conversion tables for IR 8-bit data of IR1- IR3 (There are no tables for IR 4 because the data is stored in 10 bits)
- conversion tables for VIS 6-bit data

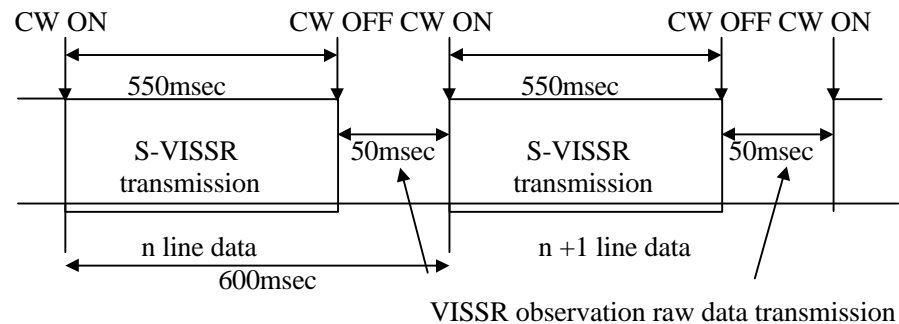

CW : Carrier Wave

Figure A S-VISSR data transmission on GMS

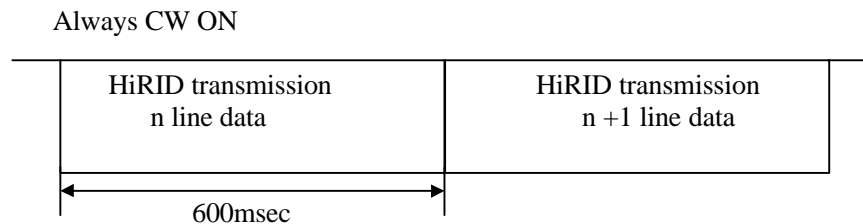

CW : Carrier Wave

Figure B HiRID data transmission on MTSAT

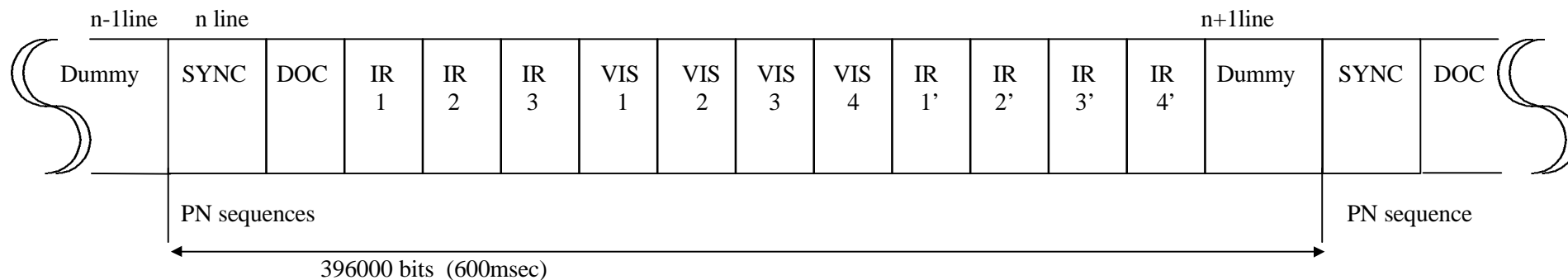

- SYNC Sync code (Fixed data of PN sequence)
- DOC Documentation sector
- IR1~IR3 8 MSBs data of IR data sectors
- VIS1~VIS4 VIS data sectors (6 bits data)
- IR1'~IR3' 2 LSBs data of IR data sectors
- IR4 IR4 data sector (10bits data)
- Dummy All logic zeros

Details of each part are shown in APPENDIX.A.

Figure C HiRID data stream

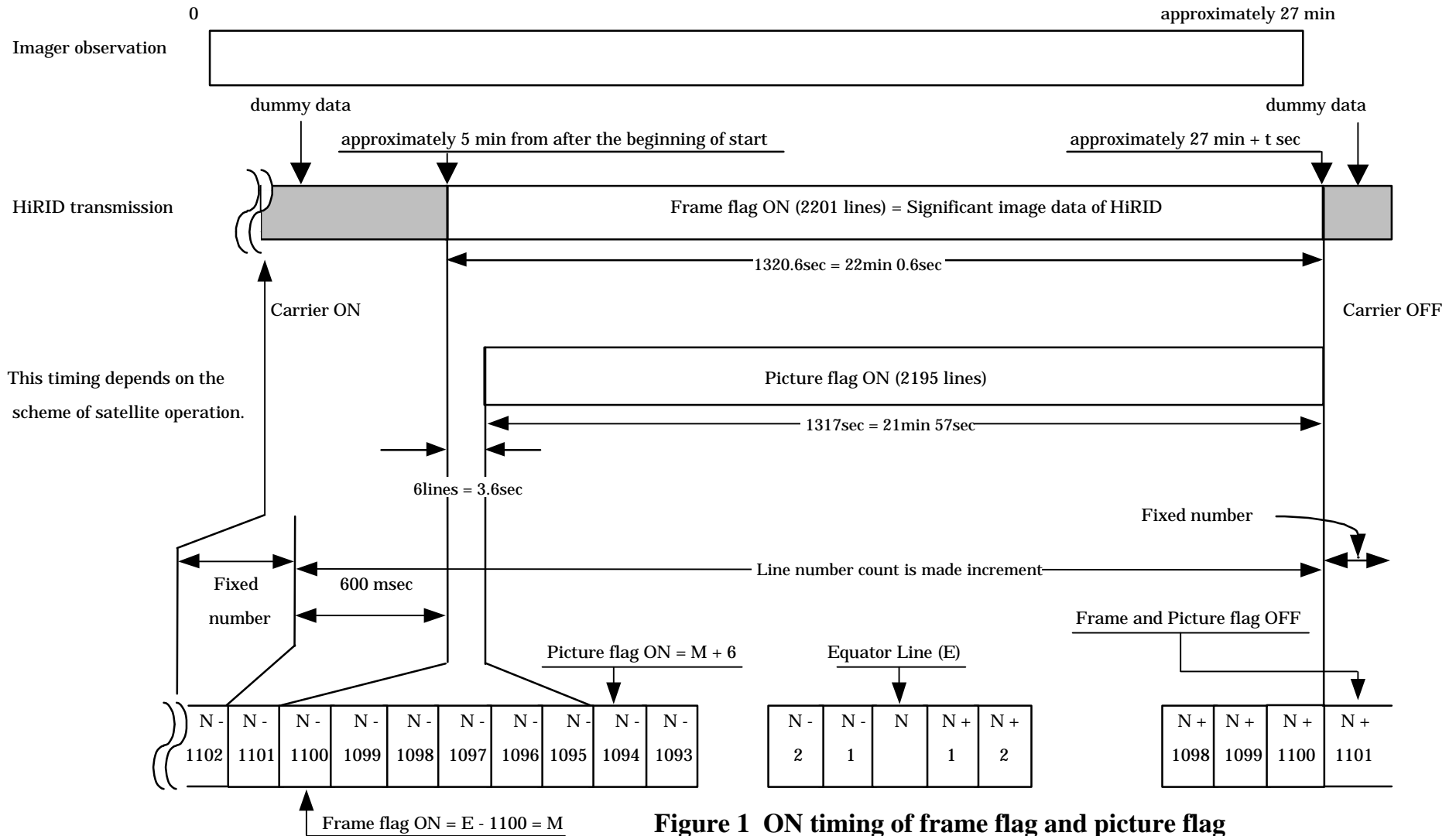

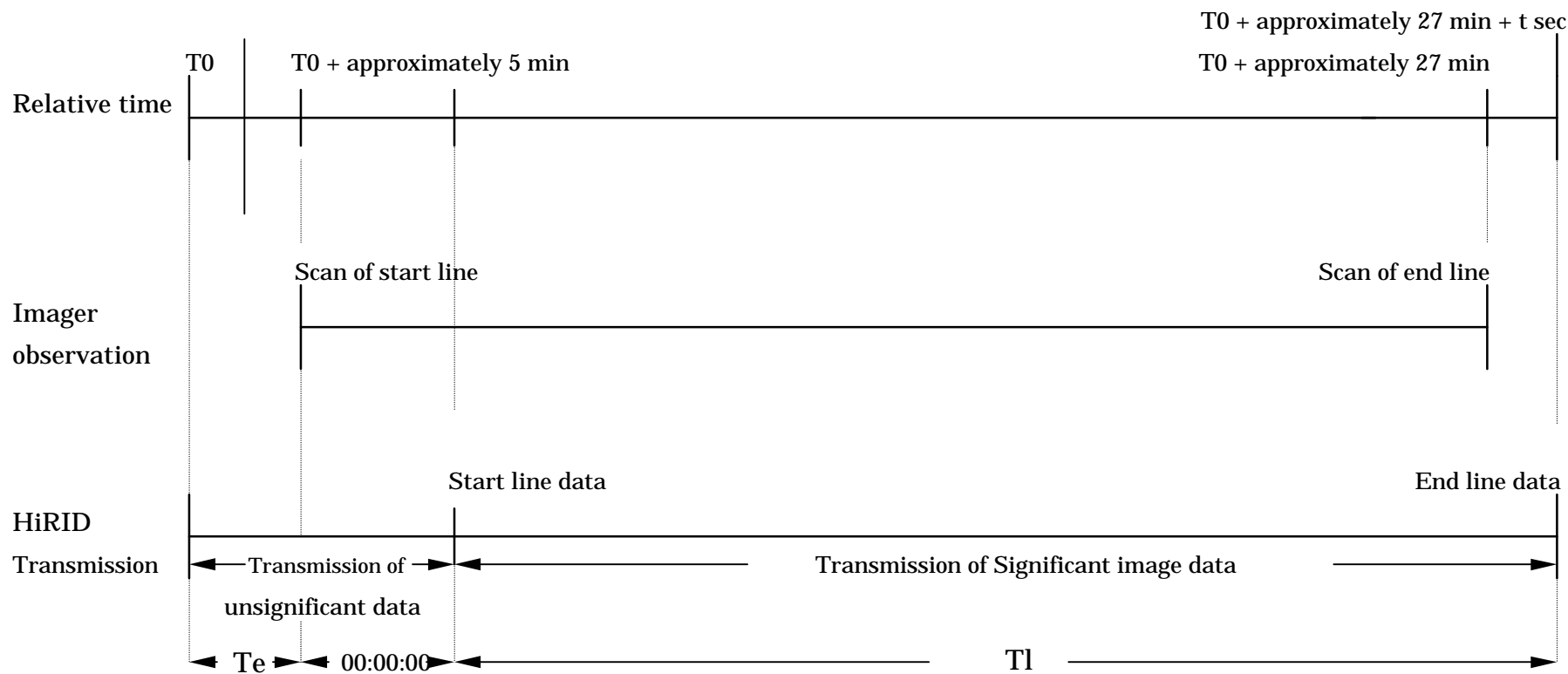

Stored time in Documentation sector of HiRID

T0: start time of the current observation

Te: observation time of end line in the last observation

Tl: observation time of each line in the current observation

Figure 2: The relation between Imager observation and HiRID transmission

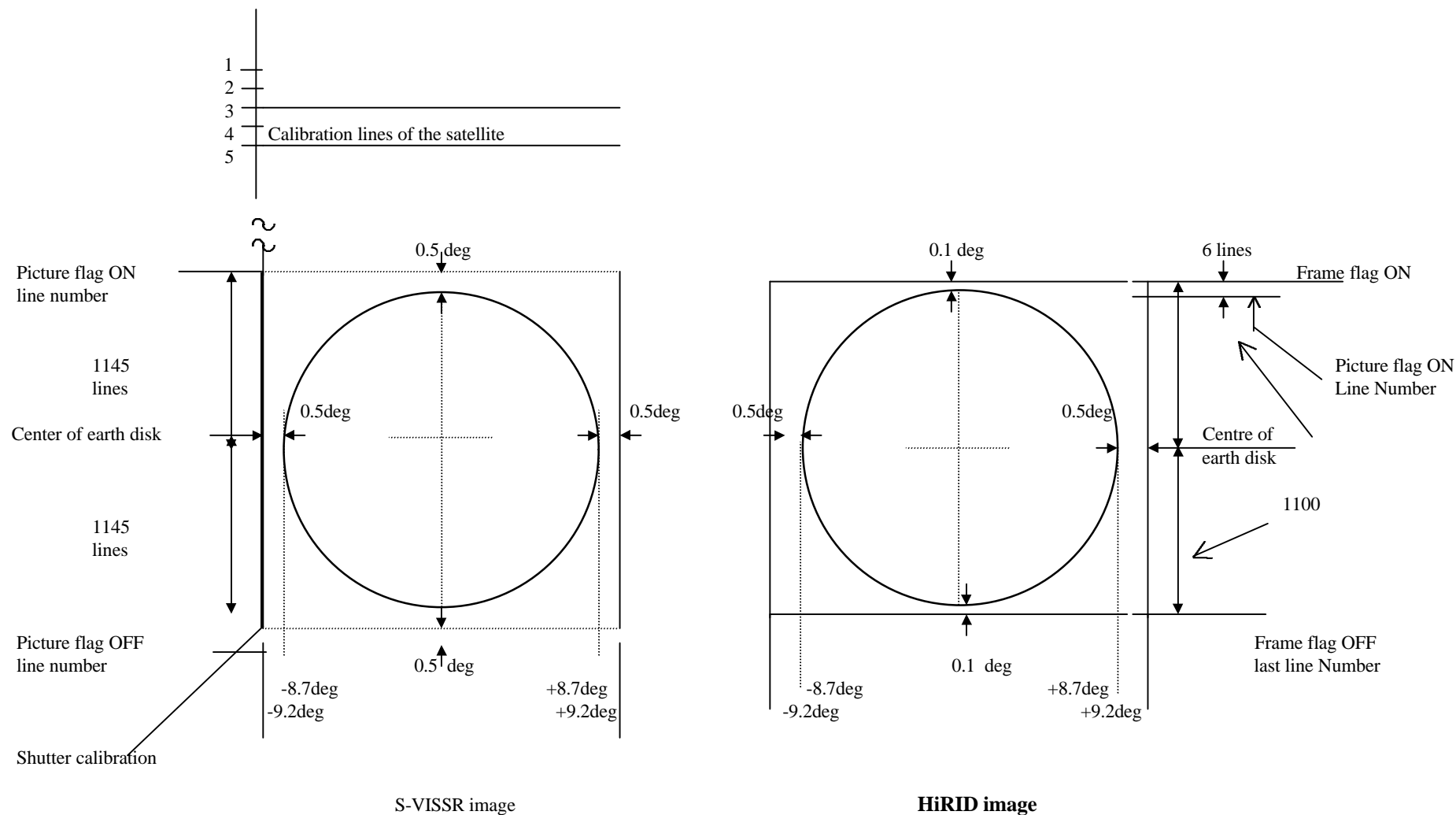
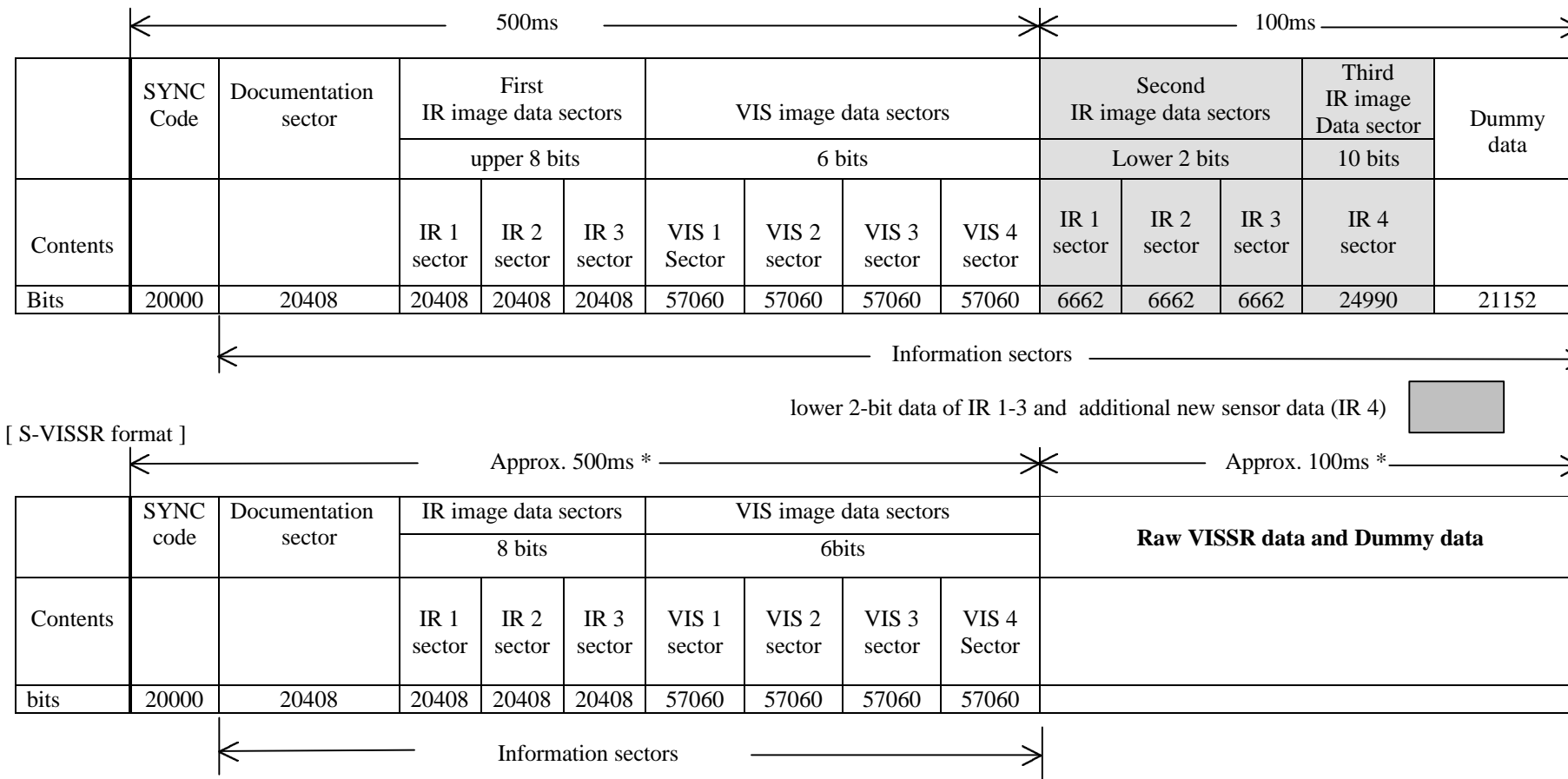

Figure 3 Dissemination frame of S-VISSR and HiRID image

HiRID format



Approx. nnn ms * : spin rate dependent

Figure 4 MTSAT HiRID format

Bits	16	1008	512	32	800	1024	3280	2048	9624	16	2048
Contents	Sector ID	Spacecraft and CDAS status block	Simplified mapping block 1	Sub-commutation ID (193-196 word)	Simplified mapping block 2	Orbit and attitude data block	MANAM Block	Calibration block	Spare block	CRC	Filler

Scan count From the line of frame flag on	193rd word	194th word Sequential sub-commutation ID (0-24)	195th word	196th word repeated data counter (0-7)	Repeated data blocks	
801	0	0	0	0	repeated data 8 lines / group	repeated text 200 lines / text 25 groups
802	0	0	0	1		
803	0	0	0	2		
804	0	0	0	3		
805	0	0	0	4		
806	0	0	0	5		
807	0	0	0	6		
808	0	0	0	7		
809	0	1	0	0		
810	0	1	0	1		
991	0	23	0	6		
992	0	23	0	7		
993	0	24	0	0		
994	0	24	0	1		
995	0	24	0	2		
996	0	24	0	3		
997	0	24	0	4		
998	0	24	0	5		
999	0	24	0	6		
1000	0	24	0	7		

Figure 5 Structure of Documentation sector and Sub-commutation ID

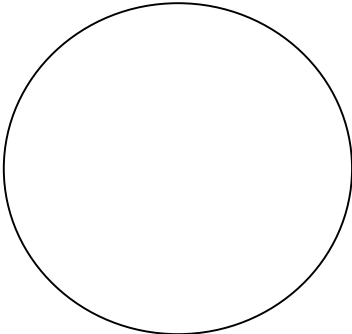
Elapsed time of the observation	Scan count from the line of frame flag on	Simplified mapping table and attitude parameters (1 text / 200 lines)	HiRID image
00 min	0001 line	Predicted data	
02	0201	Predicted data	
04	0401	Predicted data	
06	0601	Predicted data	
08	0801	First correction data	
10	1001	First correction data	
12	1201	First correction data	
14	1401	First correction data	
16	1601	First correction data	
18	1801	First correction data	
20	2001	Second correction data	
22	2201	Second correction data	

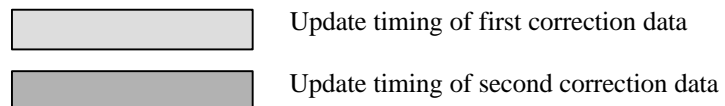

Figure 6 Update timing of the simplified mapping table and attitude parameters block

APPENDIX A - SPECIFICATIONS OF HiRID

1. Main characteristics

The principal characteristics of the physical layer are as follows.

Parameters	Contents
Frequency	1687.1 MHz
Modulation	BPSK, NRZ-M (Differential encoded)
Bit rate	660 kbps (fixed rate)
EIRP	25.0 dBW
Band width	Less than 2 MHz
Frame length	396,000 bits / including SYNC code
Coding scheme	Byte complementing and PN scrambling
Sequence of bits	Most Significant Bit (MSB) first

An example of link budget at a station is shown as follows.

Parameters	Contents
EIRP	25.00 dBW
Free space loss	189.46 dB^{*1}
G/T	10.00 dB/K^{*2}
Total C/N₀	72.63 dB Hz
Required C/N₀	71.60 dB Hz^{*3}
Margin	1.03 dB

***1 Free space loss** **42.000km (8.7 degree off beam angle)**

***2 G/T** **Antenna gain 34.80 dBi**
System noise temperature 24.80 dB°K (302°K)

***3 Required C/N₀** **Effective Eb/ N₀ 10.60 dB-Hz**
Data rate 58.20 dB-Hz
Implementation loss 2.80 dB-Hz

2. Frame Format

HiRID data format is designed to be compatible with S-VISSR as well as its transmission data rate 660kbps. Each line contains a SYNC code, information sectors and dummy data as shown in Figure A-1. The second and third infrared (IR) image data sectors with the MTSAT/Imager are provided in new sectors after VIS image sectors which was used for VISSR observation data transmission of GMS.

2.1 SYNC Code

SYNC code is transmitted to allow bit and frame synchronization by demodulators and decoders at the user station. It consists of 20,000 bits in Pseudo-random Noise (PN) sequence generated by means of a 15-digit serial shift register. It begins with the fixed pattern (010001001100001) at the beginning of every line and ends with 15 consecutive logic ones (11111111111111).

Subsequent HiRID data are encoded by the PN sequence to distribute RF energy evenly after modulation because the image data may contain consecutive logic zeros or ones. This scheme is also effective in maintaining bit-sync-lock of the MDUS demodulator.

2.2 Information Sectors

HiRID data are composed of 12 sectors and the leading 8 sectors are compatible with S-VISSR:

- Documentation sector
- First infrared image data sectors (IR1 ~ IR3) upper 8 bits of IR Image data
- Visible image data sectors (VIS1~VIS4)
- Second infrared image data sectors (IR1 ~ IR3) lower 2 bits of IR Image data
- Third image data sector (IR4)

Each image data sector has its discrimination code, that is, 16 bits of Cyclic Redundancy Check (CRC) code at the beginning of the sector and 2,048 logic zeros (Filler) at the end. One word of the VIS image data sector consists of 6 bits and that of IR sectors consists of 8 bits, respectively.

The cyclic redundancy check (CRC) code is 16 bits error detection/correction data generated by the following operational polynomial:

$$G(X) = X^{16} + X^{12} + X^5 + 1$$

All of the Fillers at the end of each data sector corresponds approximately 3 msec in transmitting time.

2.2.1 Documentation Sector

The Documentation sector is divided into the following nine information blocks:

- (1) Sector ID block
- (2) Spacecraft (S/C) and CDAS status block
- (3) Simplified mapping block 1
- (4) Sub-commutation ID block
- (5) Simplified mapping block 2
- (6) Orbit and attitude data block
- (7) MANAM block
- (8) Calibration block
- (9) Spare block

The structure of Documentation sector is shown in Figure 5 of the main text.

Blocks for Simplified mapping block 2 through spare block are disseminated by Sub-commutation technique because the volume of the data is too large to be handled once; the total volume (text) is divided into 25 blocks and each block is transmitted 8 consecutive scan lines repeatedly to reduce errors in propagation. Therefore, the transmission of a complete Documentation text requires 200 scan lines.

(1) Sector ID block

This block contains 2 words (16 bits), all logic zeros, and is used to identify the documentation sector.

(2) S/C and CDAS Status block

The block conveys information necessary to process data such as Picture Flag, Scan Count (Line Number) and Time of data acquisition in each line. It contains 126 words. (See Table A.1 for details.)

The 99th word is assigned to indicate if the navigation data are updated. Parameters concerning the navigation process are assigned to Simplified mapping block 2 and Orbit and attitude data block as shown in Table A.3 and Table A.4.

(3) Simplified mapping block 1 (constants)

This block consists of 64 words. The data in this block are used for simplified mapping together with the data in Simplified mapping block 2. (See Table A.2 for details.)

(4) Sub-commutation ID block

This block consists of 4 words. The first counter (the 194th word of Documentation) is the repeat counter indicating Sub-commutation ID and increments from 0 to 24 for the 25 Documentation text groups. The second counter (the 196th word) is also the repeat counter and increments from 0 to 7 for each repeated line of a group. The value of other words (193rd and 195th) are always set zero. A complete information block containing parameters block for simplified mapping, orbit and attitude data, MANAM and calibration data requires 200 lines.

The concept of the Sub-Commutation ID block is shown in Figure 5 of the main text.

(5) Simplified mapping block 2 (parameter table)

This block contains a part of list which indicates the mapping information between pixel coordinates and geographical coordinates. The mapping values indicate line numbers and pixel numbers of 25 by 25 grid points on an image, which correspond to the points on geographical coordinates of every 5 degrees between 60 degrees north and 60 degrees south of latitude and 80 degrees east and 160 degrees west of longitude. The format of the block is indicated in Table A.3.

The size of the entire map is 2,500 words. On the HiRID transmission sequence, the map is divided into 25 groups of 100 words, and one of 100 words groups is sent in frame as a Simplified mapping block 2. The number of the group in a frame could be identified by "Sub-commutation ID" in the Sub-commutation ID block.

The simplified mapping method uses the information included in the Simplified mapping blocks 1 and 2. Users will be able to obtain the mapping matrix easily referring the results of transformation of 5°x 5° grid points.

(6) Orbit and attitude data block

This block is maintained for the compatibility to the S-VISSR. The block contains 128 words. A text of data is composed of 3,200 words conveyed by Sub-commutation technique, which provide parameters indispensable to determine precise geometric positions of the pixels. (See Tables A.4, A.5 and A.6.)

The mapping method uses the information on the satellite's orbit and attitude included in this block. In the block, orbit and attitude data are calculated at the epoch time and are predicted for the time around the observation. Users will be able to obtain the accurate mapping matrices from these parameters.

(7) MANAM block

MANAM is the information to notify users of the operational schedule and additional information. The block consists of 10,250 words. 410 words are contained in each line. The same data (410 words) are repeated eight times to avoid missing. Therefore, 200 lines are needed in order to acquire all information of this block. The MANAM consists of 125 strings. Each string width of 82 characters includes two terminators. The strings are written in ASCII code and the terminators are carriage return (CR) and line feed (LF). The MANAM block is divided into 25 groups of five strings. And five strings (one of 25 groups) are stored in a MANAM block (410 words) and disseminated on a frame.

(8) Calibration block

The block contains 256 words. A text of calibration data is composed of 6,400 words conveyed using the Sub-commutation technique.

The level values obtained with the images are converted into physical quantity of reflection, black body radiance temperature or radiation, and are stored in this block. (See Table A.7.)

(9) Spare block

This block consists of 9,264 bits for a spare and is filled with logic zeros.

2.2.2 Infrared Image Data Sectors

Each IR sector includes 2,291 pixels as one line of image data. The spatial resolution of the IR pixel is 5 km at nadir. Quantization of IR channels are expressed using 10 bits by MTSAT but the upper 8 bits in the IR1 ~ IR3 data are provided in the first IR image data sectors in order to maintain compatibility with S-VISSR. The lower 2 bits of the IR1 ~ IR3 data are provided in the second IR image data sectors. Users may combine them to recover the complete pixel data. 3.7µm IR data are provided as IR4 data in the third IR image data sector.

The sector ID codes and IR image data are defined as follows:

IR sector ID code

Sector	word 1	word 2
IR1 (upper 8 bits data)	0 0 0 1 0 0 0 1	0 0 0 1 0 0 0 1
IR2 (upper 8 bits data)	0 0 1 0 0 0 1 0	0 0 1 0 0 0 1 0
IR3 (upper 8 bits data)	0 1 0 0 0 1 0 0	0 1 0 0 0 1 0 0
IR1 (lower 2 bits data)	1 0 0 0 1 0 0 0	1 0 0 0 1 0 0 0
IR2 (lower 2 bits data)	1 0 0 1 1 0 0 1	1 0 0 1 1 0 0 1
IR3 (lower 2 bits data)	1 0 1 0 1 0 1 0	1 0 1 0 1 0 1 0
IR4 (10 bits data)	1 0 1 1 1 0 1 1	1 0 1 1 1 0 1 1

2.2.3 Visible Image Data Sectors

Each visible sector includes 9,164 pixels of image data acquired by an Imager scan. The observation band is 0.55-0.80 μ m, and spatial resolution is 1.25 km at sub-satellite point. VIS1 ~ VIS4 data are stored in the VIS image data sectors.

The sector ID codes are defined as follows:

VIS sector code

Sector	word 1	word 2
VIS1	0 1 1 0 1 1	0 1 1 0 1 1
VIS2	1 0 1 1 0 1	1 0 1 1 0 1
VIS3	1 1 0 1 1 0	1 1 0 1 1 0
VIS4	1 1 1 1 1 1	1 1 1 1 1 1

2.3 Dummy Data

The HiRID data volume of each line is fixed to be 369,000 bits transmitted at 660 kbps and 21,152 encoded logic zeros are provided as the dummy data to complete one line, followed by Sync code of the next line. The HiRID transmission will start and terminate coincidentally with the Imager operation without interruption by the transmission of Imager observation data.

3. Coding method

Two stages of coding scheme are applied to HiRID data transmission for the purpose of RF energy distribution and maintaining sync-lock of MDUS demodulators which may lose sync-lock on incoming data when logic ones or zeros continue.

3.1 Byte Complementing

The first stage of coding is the byte complementing. It starts at the beginning of the information sectors. Every other 8 bits (logic zeros and ones) of the original HiRID data are inverted (complemented every even byte). It continues down to the end of Dummy data. Note that the byte complement is not applied to SYNC code.

3.2 PN Scrambling

The second stage of coding involves the output bit stream of the SYNC code generator described in section 2.1. Byte complemented HiRID data are scrambled by the generator output using an exclusive OR gate before PSK modulation for dissemination. Descrambling schematic of PN coded HiRID data is described in **Figure A-2**.

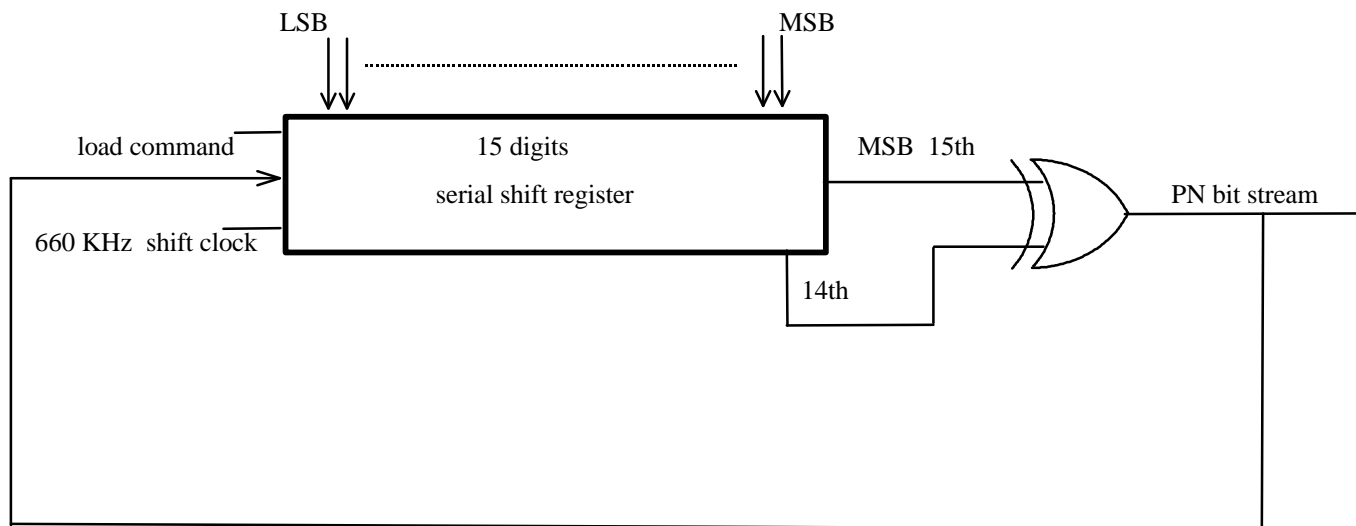

Figure A-2 PN pattern generator circuitry

Table A.1(continued)

Word No.	Type	Contents	Description
7 - 8	BCD*2	Picture flag Reset Line Number Line number insignificant picture flag	Line Number when Picture Flag turned to OFF.
9 - 10	BCD*2	Scan Count (1) Scan Count Converted Decimal	Scan Count expressed in decimal It indicates.
11 - 12	I*2	West Horizon Point Pixel count of IR data at the Earth edge (12 bit binary) When the edge can't be detected or Q/D Error : FFFF ₍₁₆₎ (MSB : 11 word-b4, LSB : 12 word-b1)	Earth Edge Position of west side at the line in HiRID image.
13 - 14	I*2	East Horizon Point Pixel count of IR data at the Earth edge (12 bit binary) When the edge can't be detected or Q/D Error : FFFF ₍₁₆₎ (MSB : 13 word-b4, LSB : 14 word-b1)	Earth Edge Position of east side at the line in HiRID image.
15	I*1	Sync lock Q/D Error information of this HiRID line 00 ₍₁₆₎ Normal FF ₍₁₆₎ Error	This item indicates the error information of the line. It depends on "Bit Error Count"(Line quality).
16 - 17	I*2	Bit Error Count Line quality of this HiRID line (13 bit binary) Line quality bad FFFF ₍₁₆₎	This item indicates the estimated line quality of the HiRID line.
18 - 19	BCD*2	Year	Year, the first block in the first line of Imager Observation Data is received time.

Table A.1 (continued)

Word No.	Type	Contents	Description
20 21 22	BCD*1	Month (01-12) Day (01-31) Hour (00-23)	Day when the first block in the first line of Imager Observation Data is received. Hour (estimated time) means the time when the line was observed.
23 24 25	BCD*1	Minute (00-59) Second (00-59) 1/100 second (00-99)	These time (estimated time) mean the time when the line was observed.
26 - 27	I*2	Calibration Table ID (16 bit binary) (MSB : 26 word-b8, LSB : 27 word-b1)	Fixed value (In case of update, it is enforced after a notice.)
28 - 29	I*2	MANAM Revision Number (16 bit binary) (MSB : 28 word-b8, LSB : 29 word-b1)	Revision Number of MANAM data which contains 1 week distribution schedule.
30	I*1	Data Source FF ₍₁₆₎ Operation Data 00 ₍₁₆₎ Test Data	Type of the data which is used for creating the HiRID image.
31- 64		Spare	
65	I*1	Scanner Select FF ₍₁₆₎ Side-1 00 ₍₁₆₎ Side-2	Type of the scanner which is used for observing the data.
66 - 67	I*2	Scan Count (2) (12 bit binary) Q/D Error FFFF ₍₁₆₎ (MSB : 66 word-b4, LSB : 67 word-b1)	HiRID line number is indicated with a binary.

Table A.1 (continued)

Word No.	Type	Contents	Description								
68	I*1	Sensor Select Sensor type is set into below bits. MSB LSB <table border="1" style="margin-left: auto; margin-right: auto;"> <tr> <td>b₈</td><td>b₇</td><td>b₆</td><td>b₅</td><td>b₄</td><td>b₃</td><td>b₂</td><td>b₁</td> </tr> </table> b ₈ : VIS4 b ₇ : VIS3 b ₆ : VIS2 b ₅ : VIS1 b ₄ : IR3 b ₃ : IR2 b ₂ : IR1 b ₁ : always“1” b ₈ -b ₁ are set the detector type. 1 : Side 1 0 : Side 2	b ₈	b ₇	b ₆	b ₅	b ₄	b ₃	b ₂	b ₁	Type of each sensor which is used for observing the data.
b ₈	b ₇	b ₆	b ₅	b ₄	b ₃	b ₂	b ₁				
69	I*1	Sensor Patch Indicates which VIS sensor's data inserted in each VIS sensor MSB LSB <table border="1" style="margin-left: auto; margin-right: auto;"> <tr> <td>b₈</td><td>b₇</td><td>b₆</td><td>b₅</td><td>b₄</td><td>b₃</td><td>b₂</td><td>b₁</td> </tr> </table> V4 V3 V2 V1 V1 : 00 V2 : 01 V3 : 10 V4 : 11	b ₈	b ₇	b ₆	b ₅	b ₄	b ₃	b ₂	b ₁	Fixed value
b ₈	b ₇	b ₆	b ₅	b ₄	b ₃	b ₂	b ₁				
70 - 72	I*3	Beta Count (24 bit binary) Beta value when the line is observed [rad] (24 bit binary) (MSB : 70 word-b8, LSB : 72 word-b1)	This item is calculated from the direction of Yaw-axis.								

Table A.1(continued)

Word No.	Type	Contents	Description								
90	I*1	S/C ID Satellite ID Number (8 bit binary)	Distinction of satellite								
91 - 93	I*3	Analog Sun Pulse Angle Analog Sun Pulse Angle 0 (Fixed) Q/D Error : FFFFFFFF ₍₁₆₎	Fixed value (Except Q/D error)								
94 - 96	I*3	PLL Error Tracking error of spin tracking loop 0 (Fixed)	Fixed value								
97	I*1	Scanner Expanded Mode Scanner Expanded Mode FF (Fixed)	Fixed value								
98	I*1	Bit and Frame SYNC ID Line Error Flag (2 bit) MSB <table border="1" style="display: inline-table; vertical-align: middle;"><tr><td>0</td><td>0</td><td>0</td><td>0</td><td>0</td><td>0</td><td>b₂</td><td>b₁</td></tr></table> LSB 00 ₍₁₆₎ Normal 03 ₍₁₆₎ Error	0	0	0	0	0	0	b ₂	b ₁	This item indicates the error information of the line. It depends on "Bit Error Count"(Line quality).
0	0	0	0	0	0	b ₂	b ₁				

Table A.1 (continued)

Word No.	Type	Contents	Description
99	I*1	Navigation information updating flag 00 ₍₁₆₎ The old (The navigation data which is predicted with the last observation data) 0F ₍₁₆₎ The first updating FF ₍₁₆₎ The second updating	This flag is used for the identification of navigation information (orbit / attitude data block and simplified mapping block 2).
100 - 126		Spare	

Table A.2 Simplified mapping block 1 (constants) (64 words)

Word No.	Type	Contents	Description
1 - 4	I*	Earth Radius(m): Equatorial Radius of the Earth	Equatorial Radius of the Earth (Fixed value)
5 - 8	I*	Satellite Elevation (m)	Satellite Elevation (Fixed value)
9 -12	I*	Stepping Angle for IR sensor (n rad)	Stepping Angle for IR sensor (Fixed value)
13 - 16	I*	Sampling Angle for IR sensor (n rad)	Sampling Angle for IR sensor (Fixed value)
17 - 20	I*	Latitude of Sub-satellite Point (m DEG)	Latitude of Sub-satellite Point (Fixed value)
21 - 24	I*	Longitude of Sub-satellite Point (m DEG)	Longitude of Sub-satellite Point (Fixed value)
25 - 28	I*	IR1 Line Number of Sub-satellite Point	IR1 Line Number of Sub-satellite Point (Fixed value)
29 - 32	I*	IR1 Pixel Number of Sub-satellite Point	IR1 Pixel Number of Sub-satellite Point (Fixed value)
33 - 36	R*4.7	Ratio of Circumference	Ratio of Circumference (Fixed value)
37 - 40	R*4.2	Sensor Mis-registration for Line Number (X_1): $L_{VIS} = (L_{IR1} - 1) \times 4 + 2.5 X_1$ L_{VIS} : line number of VIS sensor L_{IR1} : line number of IR1 sensor	Fixed value (=0)
41 - 44	R*4.2	Sensor Mis-registration for Pixel Number (Y_1): $P_{VIS} = (P_{IR1} - 1) \times 4 + 2.5 Y_1$ P_{VIS} : Pixel number of VIS sensor P_{IR1} : Pixel number of IR1 sensor	Fixed value (=0)
45 - 48	R*4.2	Sensor Mis-registration for Line Number (X_2): $L_{IR2} = L_{IR1} + X_2$ L_{IR2} : line number of IR2 sensor L_{IR1} : line number of IR1 sensor	Fixed value (=0)
49 - 52	R*4.2	Sensor Mis-registration for Pixel Number (Y_2): $P_{IR2} = P_{IR1} + Y_2$ P_{IR2} : Pixel number of IR2 sensor P_{IR1} : Pixel number of IR1 sensor	Fixed value (=0)

Table A.2 (Continued)

Word No.	Type	Contents	Description
53 - 56	R*4.2	Sensor Mis-registration for Line Number (X_3): $L_{WV} = L_{IR1} + X_3$ L_{WV} : line number of WV sensor L_{IR1} : line number of IR1 sensor	Fixed value (=0)
57 - 60	R*4.2	Sensor Mis-registration for Pixel Number (Y_3): $P_{WV} = P_{IR1} + Y_3$ P_{WV} : Pixel number of WV sensor P_{IR1} : Pixel number of IR1 sensor	Fixed value (=0)
61 - 64		Spare	

Table A.3 Simplified mapping block 2 (parameters) (2500 words)

Word No.	Type	Contents	Description
1, 2	I*2	Line number of 60°N, 80°E	Line Number of 60°N, 80°E of HiRID IR Data
3, 4	I*2	Pixel number of 60°N, 80°E	Pixel Number of 60°N, 80°E of HiRID IR Data
5, 6	I*2	Line number of 60°N, 85°E	Line Number of 60°N, 85°E of HiRID IR Data
7, 8	I*2	Pixel number of 60°N, 85°E	Pixel Number of 60°N, 85°E of HiRID IR Data
9, 10	I*2	Line number of 60°N, 90°E	Line Number of 60°N, 90°E of HiRID IR Data
11, 12	I*2	Pixel number of 60°N, 90°E	Pixel Number of 60°N, 90°E of HiRID IR Data
101, 102	I*2	Line number of 55°N, 80°E	Line Number of 55°N, 80°E of HiRID IR Data
103, 104	I*2	Pixel number of 55°N, 80°E	Pixel Number of 55°N, 80°E of HiRID IR Data
105, 106	I*2	Line number of 55°N, 85°E	Line Number of 55°N, 85°E of HiRID IR Data
107, 108	I*2	Pixel number of 55°N, 85°E	Pixel Number of 55°N, 85°E of HiRID IR Data
2493, 2494	I*2	Line number of 60°S, 165°W	Line Number of 60°S, 165°W of HiRID IR Data
2495, 2496	I*2	Pixel number of 60°S, 165°W	Pixel Number of 60°S, 165°W of HiRID IR Data
2497, 2498	I*2	Line number of 60°S, 160°W	Line Number of 60°S, 160°W of HiRID IR Data
2499, 2500	I*2	Pixel number of 60°S, 160°W	Pixel Number of 60°S, 160°W of HiRID IR Data

Table A.4 Orbit and attitude data block (3200 words)

Word No.	Type	Contents	Description
1 - 6	R*6.8	Observation start time (MJD)	Time (Estimated) of observation start.
7 - 10	R*4.8	VIS channel Stepping Angle along line (rad)	VIS channel Stepping Angle along Line (Fixed value)
11 - 14	R*4.8	IR channel Stepping Angle along line (rad)	IR channel Stepping Angle along Line (Fixed value)
15 - 18	R*4.10	VIS channel Sampling Angle along pixel (rad)	VIS channel Sampling Angle along Pixel (Fixed value)
19 - 22	R*4.10	IR channel Sampling Angle along pixel (rad)	IR channel Sampling Angle along Pixel (Fixed value)
23 - 26	R*4.4	VIS channel centre line number of VISSR frame	VIS channel Centre Line Number of HiRID (Fixed value)
27 - 30	R*4.4	IR1 channel centre line number of VISSR frame	IR-I channel Centre Pixel Number of HiRID (Fixed value)
31 - 34	R*4.4	VIS channel centre pixel number of VISSR frame	VIS channel Centre Line Number of HiRID (Fixed value)
35 - 38	R*4.4	IR1 channel centre pixel number of VISSR frame	IR-I channel Centre Pixel Number of HiRID (Fixed value)
39 - 42	R*4.0	Number of Sensors of VIS channel	Number of Sensors of VIS channel (Fixed value)
43 - 46	R*4.0	Number of Sensors of IR channel	Number of Sensors of IR channel (Fixed value)
47 - 50	R*4.0	VIS total line number of VISSR frame	VIS channel Total Line Number
51 - 54	R*4.0	IR total line number of VISSR frame	IR channel Total Line Number
55 - 58	R*4.0	VIS pixel number of one line	VIS channel Total Pixel Number
59 - 62	R*4.0	IR pixel number of one line	IR channel Total Pixel Number
63 - 66	R*4.10	VISSR misalignment angle around x-axis (rad)	Fixed value (= 0)
67 - 70	R*4.10	VISSR misalignment angle around y-axis (rad)	Fixed value (= 0)
71 - 74	R*4.10	VISSR misalignment angle around z-axis (rad)	Fixed value (= 0)

Table A.4 (Continued)

Word No.	Type	Contents	Description
75 - 78	R*4.7	Element of VISSR misalignment matrix on	Fixed value
79 - 82	R*4.10	row 1 and column 1	
83 - 86	R*4.10	row 2 and column 1	
87 - 90	R*4.10	row 3 and column 1	
91 - 94	R*4.7	row 1 and column 2	
95 - 98	R*4.10	row 2 and column 2	
99 - 102	R*4.10	row 3 and column 2	
103 - 106	R*4.10	row 1 and column 3	
107 - 110	R*4.7	row 2 and column 3	
111 - 114	R*4.4	IR2 channel centre line number of VISSR frame	IR-II channel Centre Line Number of HiRID (Fixed value)
115 - 118	R*4.4	IR3 channel centre line number of VISSR frame	IR-III channel Centre Line Number of HiRID (Fixed value)
119 - 122	R*4.4	IR2 channel centre pixel number of VISSR frame	IR-II channel Centre Pixel Number of HiRID (Fixed value)
123 - 126	R*4.4	IR3 channel centre pixel number of VISSR frame	IR-III channel Centre Pixel Number of HiRID (Fixed value)
127 - 128		Spare	
129 - 132	R*4.7	Constants - Ratio of Circumference	Ratio of Circumference π (Fixed value)
133 - 136	R*4.9	- Ratio of Circumference /180	$\pi / 180$ (Fixed value)
137 - 140	R*4.6	- 180 / Ratio of Circumference	$180 / \pi$ (Fixed value)
141 - 144	R*4.1	- Equatorial Radius of the Earth (m)	Equatorial Radius of the Earth (Fixed value)
145 - 148	R*4.10	- Oblateness of the Earth	Oblateness of the Earth (Fixed value)
149 - 152	R*4.9	- Eccentricity of the Earth	Eccentricity of the Earth (Fixed value)
153 - 156	R*4.8	- Angle between the VISSR and the View Direction of the Sun Sensor (rad)	Angle of Data acquisition start (Fixed value)

Table A.4 (Continued)

Word No.	Type	Contents	Description
157 - 162	R*6.8	Orbital Parameters in mean of 1950.0 - Epoch Time of Orbital Parameters (MJD)	Epoch Time of Orbital Element
163 - 168	R*6.8	- Semi-major Axis (km)	Semi-major Axis
169 - 174	R*6.10	- Eccentricity	Eccentricity
175 - 180	R*6.8	- Inclination (deg)	Orbital Inclination
181 - 186	R*6.8	- Longitude of Ascending Node (deg)	Longitude of Ascending Node
187 - 192	R*6.8	- Argument of Perigee (deg)	Argument of Perigee
193 - 198	R*6.8	- Mean Anomaly (deg)	Mean Anomaly
199 - 204	R*6.6	- Sub-satellite East Longitude (deg)	East Longitude of Sub Satellite Point
205 - 210	R*6.6	- Sub-satellite North Longitude (deg)	North Latitude of Sub Satellite Point
211 - 216	R*6.8	Attitude Parameters in mean of 1950.0 - Epoch Time of Attitude Parameters (MJD)	Epoch Time of Attitude Parameters
217 - 222	R*6.8	- Angle between Z-axis and Satellite Spin Axis projected on yz-plane α_r (rad)	Angle and change-rate between Pitch-axis and Z-axis
223 - 228	R*6.15	- Change-rate of α_r (rad/sec)	
229 - 234	R*6.11	- Angle between Satellite Spin Axis and yz-plane δ_r (rad)	
235 - 240	R*6.15	- Change-rate of δ_r (rad/sec)	
241 - 246	R*6.8	- Daily Mean of Satellite Spin Rate (rpm)	Value (Estimated) of Spin Rate
247 - 256		Spare	

Table A.4 (Continued)

Word No.	Type	Contents	Description
257 -896		Attitude Prediction Data Sub-blocks 1 through 10 (10 similar attitude prediction data sub-blocks are repeated - for details see Table A.5)	Please refer to Table A.5
897 - 2944		Orbit Prediction Data Sub-blocks 1 through 8 (8 similar orbit prediction data sub-blocks are repeated - for details see Table A.6)	Please refer to Table A.6
2945 - 2950	R*6.8	Time of the First Attitude Prediction Data (MJD)	Time of the first attitude prediction record (Attitude Prediction Data Block)
2951 - 2956	R*6.8	Time of the Last Attitude Prediction Data (MJD)	Time of the Last attitude prediction record (Attitude Prediction Data Block)
2957 - 2962	R*6.8	Interval Time of Attitude Prediction Data (MJD)	Fixed value (0.00347222)
2963 - 2964	I*2	Number of Attitude Prediction Data	Number of Attitude Prediction Data Block (= 10)
2965 - 2970	R*6.8	Time of the First Orbital Prediction Data (MJD)	Time of the first orbit prediction record (Orbit Prediction Data Block)
2971 - 2976	R*6.8	Time of the Last Orbital Prediction Data (MJD)	Time of the Last orbit prediction record (Orbit Prediction Data Block)
2977 - 2982	R*6.8	Interval Time of Orbital Prediction Data (MJD)	Fixed value (0.00347222)
2983 - 2984	I*2	Number of Orbit Prediction Data	Number of Orbit Prediction Data Block (= 8)
2985 - 3200		Spare	

Table A.5 Contents of attitude prediction data sub-block (64 words)

Word No.	Type	Contents (position means a relative address in the block)	Description
1 - 6	R*6.8	Prediction time (UTC represented in MJD)	Time (UTC) when the attitude prediction is processed.
7 - 12	BCD*6	Anno Domini represented by BCD (YYMMDDHHmmSS; Year,Month,Day,Hour,Minute,Second)	Time when the attitude prediction is processed. It is expressed by BCD.
13 - 18	R*6.8	Angle between z-axis and satellite spin axis projected on yz-plane in mean of 1950.0 coordinates (rad)	Angle between Pitch-axis and Z-axis (on YZ-plane)
19 - 24	R*6.11	Angle between satellite spin axis and yz-plane in mean of 1950.0 coordinates (rad)	Angle between Pitch-axis and YZ-plane
25 - 30	R*6.8	Dihedral Angle between the Sun and the Earth measured clockwise seeing from North (rad)	Angle between Yaw-axis and the nominal direction.
31 - 36	R*6.8	Spin Rate: spin speed of satellite (rpm)	Value (Estimated) of Spin Rate
37 - 42	R*6.8	Right Ascension of satellite spin axis in the Satellite Orbit Plane Coordinate System (rad)	Right Ascension on the Satellite Orbit Plane Coordinate System at the Attitude Epoch
43 - 48	R*6.8	Declination and otherwise same as above	Declination and otherwise same as above
49 - 64		Spare	

Table A.6 Contents of orbit prediction data sub-block (256 words) (position means a relative address in the block)

Word No.	Type	Contents (position means a relative address in the block)	Description
1 - 6	R*6.8	Prediction time (UTC represented in MJD)	Orbit Prediction Time(UTC)
7 - 12	BCD*6	Anno Domini represented by BCD (YYMMDDHHmmSS; Year,Month,Day,Hour,Minute,Second)	Orbit Prediction Time is expressed by BCD.
13 - 18	R*6.6	X component of satellite position in mean of 1950.0 coordinates (m)	These are calculated from nominal orbit to project a pixel to Fixed Earth Projection.
19 - 24	R*6.6	Y component of satellite position in mean of 1950.0 coordinates (m)	
25 - 30	R*6.6	Z component of satellite position in mean of 1950.0 coordinates (m)	
31 - 36	R*6.8	X component of satellite velocity in mean of 1950.0 coordinates (m/s)	
37 - 42	R*6.8	Y component of satellite velocity in mean of 1950.0 coordinates (m/s)	
43 - 48	R*6.8	Z component of satellite velocity in mean of 1950.0 coordinates (m/s)	
49 - 54	R*6.6	X component of satellite position in the earth-fixed coordinates (m)	These are calculated from the longitude of SSP and the radius of orbit.
55 - 60	R*6.6	Y component of satellite position in the earth-fixed coordinates (m)	
61 - 66	R*6.6	Z component of satellite position in the earth-fixed coordinates (m)	Fixed value(= 0)
67 - 72	R*6.10	X component of satellite velocity in the earth-fixed coordinates (m/s)	These are calculated from the longitude of SSP and the radius of orbit.
73 - 78	R*6.10	Y component of satellite velocity in the earth-fixed coordinates (m/s)	
79 - 84	R*6.10	Z component of satellite velocity in the earth-fixed coordinates (m/s)	Fixed value(= 0)
85 - 90	R*6.8	Greenwich sidereal time in true of data coordinates (deg)	Greenwich sidereal Time in True of Date System
91 - 96	R*6.8	Right ascension from the satellite to the sun in mean of 1950.0 coordinates (deg)	These are calculated from nominal orbit to project a pixel to Fixed Earth Projection.
97 - 102	R*6.8	Declination from the satellite to the sun in mean of 1950.0 coordinates (deg)	
103 - 108	R*6.8	Right ascension from the satellite to the sun in the earth-fixed coordinates (deg)	
109 - 114	R*6.8	Declination from the satellite to the sun in the earth-fixed coordinates (deg)	

Table A.6 (continued)

Word No.	Type	Contents	Description
115 - 128		Spare	
129 - 134	R*6.12	Element of nutation and precession matrix	These are calculated from the time in the orbit prediction data file.
135 - 140	R*6.14	row 1 and column 1	
141 - 146	R*6.14	row 2 and column 1	
147 - 152	R*6.14	row 3 and column 1	
153 - 158	R*6.12	row 1 and column 2	
159 - 164	R*6.12	row 2 and column 2	
165 - 170	R*6.16	row 3 and column 2	
171 - 176	R*6.12	row 1 and column 3	
177 - 182	R*6.16	row 2 and column 3	
183 - 188	R*6.12	row 3 and column 3	North Latitude of Sub-satellite Point
189 - 194	R*6.8	Sub-satellite Point: North Latitude (deg)	East Longitude of Sub-satellite Point
195 - 200	R*6.8	Sub-satellite Point: East Longitude (deg)	Satellite Altitude from Surface
201 - 256	R*6.6	Height of the Satellite above the Earth Surface (m)	
		Spare	

Table A.7 Calibration data block (6400 words)

Word No.	Type	Contents		Description
1 - 4	I*4	Calibration information ID		
5 - 10	BCD*6	Data generated date (YYYY.MM.DD.HH.mm)		Creating Time of Calibration Table
11	I*1	Sensor selection : 1 - said 1 , 2 - said 2		Type of the scanner which is used for observing the data.
12 - 256		Spare		
257 - 512	R*4.6×64	VIS1 VIS level-albedo conversion table	257 - 260 R*4.6 albedo of 0 level 261 - 264 R*4.6 albedo of 1 level 265 - 268 R*4.6 albedo of 2 level 509 - 512 R*4.6 albedo of 64 level	Fixed value
513 - 768	R*4.6×64	Same above but VIS2	same as above but position	Same as above
769 - 1024	R*4.6×64	Same above but VIS3	same as above but position	Same as above
1025 - 1280	R*4.6×64	Same above but VIS4	same as above but position	Same as above
1281 - 2304	R*4.3×256	IR 1 IR Level-temperature conversion table	1281 - 1284 R*4.3 temperature of 0 level (K) 1285 - 1288 R*4.3 temperature of 1 level (K) 1289 - 1282 R*4.3 temperature of 2 level (K) 2301 - 2304 R*4.3 temperature of 255 level (K)	Same as above

Table A.7 (continued)

Word No.	Type	Contents		Description
2305 - 3328	R*4.3×256	same above but IR2	same as above but position	Same as above
3329 - 4352	R*4.3×256	same above but IR3	same as above but position	Same as above
4253 - 6400		Spare		

APPENDIX B - Sample Program of MTSAT HiRID and GMS-5 S-VISSR image navigation

```

C *****
C
C          +=====+      +-----+ BLOCK LENGTH :
C          ! S-VISSR !<----! S-VISSR DATA ! 9174 BYTES
C          ! NAV.   !      +-----+ (FIXED LENGTH)
C          ! DATA  !      UNIT=10 (DISK)
C          ! CHECK  !
C +-----+ ! PROGRAM !
C ! LISTING !<----! <SV0000>!
C +-----+ +=====+
C UNIT=6
C
C          +--      +-----+
C          !      1 ! DOCUMENTATION SECTOR DATA / !
C          !      ! IR1, IR2, IR3 DATA !
C          !      +-----+
C          !      2 ! VIS 1 DATA !
C          !      +-----+
C          1 SCAN LINE 3 ! VIS 2 DATA !
C          ==> 5 BLOCKS +-----+
C          !      4 ! VIS 3 DATA !
C          !      +-----+
C          !      5 ! VIS 4 DATA !
C          +--      +-----+
C          <-----9174 BYTES----->
C
C
C
C
C *****
C          PROGRAM SV0000
C-----
C          GMS-5 S-VISSR AND MTSAT HiRID NAVIGATION
C-----
C          INTEGER*4 ISMT(25,25,4),JSMT(25,25,4),IX(25)/25*0/
C          INTEGER*4 JWEL1/0/,JWEL2/0/,ITC/0/,LAEDG(2),LEEDG(2)
C          REAL*4 WEL1(100)/100*0/,WEL2(100)/100*0/,
C          . WEL3(100)/100*0/,WEL4(100)/100*0/
C          REAL*4 RINF(8)
C          REAL*8 DSCT
C          CHARACTER CSMT(2500)*1,COBAT(3200)*1
C          CHARACTER CBUF(9174)*1,DATID*2,SCTID*2,COND*128,MAPC*64,
C          . TEXTID*4,MAPTBL*100,OBAT*128,MANAM*410,SPARE*1459,
C          . SCTCD1*2,SCTCD2*2,SCTCD3*2,CMAPC*64
C          EQUIVALENCE ( CBUF( 1)(1:1), DATID(1:1) )
C          EQUIVALENCE ( CBUF( 3)(1:1), SCTID(1:1) )
C          EQUIVALENCE ( CBUF( 5)(1:1), COND(1:1) )
C          EQUIVALENCE ( CBUF( 131)(1:1), MAPC(1:1) )
C          EQUIVALENCE ( CBUF( 195)(1:1), TEXTID(1:1) )
C          EQUIVALENCE ( CBUF( 199)(1:1), MAPTBL(1:1) )
C          EQUIVALENCE ( CBUF( 299)(1:1), OBAT(1:1) )
C          EQUIVALENCE ( CBUF( 427)(1:1), MANAM(1:1) )
C          EQUIVALENCE ( CBUF( 837)(1:1), SPARE(1:1) )
C          EQUIVALENCE ( CBUF(2296)(1:1), SCTCD1(1:1) )
C          EQUIVALENCE ( CBUF(4589)(1:1), SCTCD2(1:1) )
C          EQUIVALENCE ( CBUF(6882)(1:1), SCTCD3(1:1) )
C
C          *OPEN FILE
C          OPEN(UNIT=10,ACCESS='DIRECT',RECL=9174,IOSTAT=IOS)
C          IF( IOS.NE.0 ) GO TO 9000
C
C          *GET MAPPING DATA
C          DO 1000 IBLK=801*5,2500*5,5
C
C          +READ S-VISSR DATA
C          READ(UNIT=10,REC=IBLK,FMT='(91(100A1),74A1)',IOSTAT=IOS) CBUF
C          IF( IOS.NE.0 ) GO TO 8000
C
C          +DOCUMENTAION SECTOR ?
C          IF( ICHAR(SCTID(1:1)).NE.0 .OR. ICHAR(SCTID(2:2)).NE.0 )

```

MTSAT HiRID Technical Information
Issue 3, 1 June 1999

```

      R4DAT = SNGL( R8DAT )
    ELSEIF( IWORD.EQ.6 ) THEN
      IDATA1 = ICHAR( C(1)(1:1) )/128
      R8DAT = DFLOAT( MOD( ICHAR( C(1)(1:1) ),128) )*2.DO**(8*5)+
      .      DFLOAT( ICHAR( C(2)(1:1) ) )*2.DO**(8*4)+
      .      DFLOAT( ICHAR( C(3)(1:1) ) )*2.DO**(8*3)+
      .      DFLOAT( ICHAR( C(4)(1:1) ) )*2.DO**(8*2)+
      .      DFLOAT( ICHAR( C(5)(1:1) ) )*2.DO**(8*1)+
      .      DFLOAT( ICHAR( C(6)(1:1) ) )
      R8DAT = R8DAT/10.DO**IPOS
      IF( IDATA1.EQ.1 ) R8DAT = -R8DAT
      R4DAT = SNGL( R8DAT )
    ENDIF
  RETURN
END
SUBROUTINE SV0110( IWORD, C, I4DAT )
C-----
C  TYPE CONVERT ROUTINE ( I-TYPE )
C-----
      INTEGER*4  IWORD,I4DAT
      CHARACTER  C(*)*1
      I4DAT = 0
      IF( IWORD.EQ.2 ) THEN
        I4DAT = ICHAR( C(1)(1:1) )*2**(8*1)+
        .      ICHAR( C(2)(1:1) )
      ELSEIF( IWORD.EQ.4 ) THEN
        I4DAT = ICHAR( C(1)(1:1) )*2**(8*3)+
        .      ICHAR( C(2)(1:1) )*2**(8*2)+
        .      ICHAR( C(3)(1:1) )*2**(8*1)+
        .      ICHAR( C(4)(1:1) )
      ENDIF
  RETURN
END
SUBROUTINE SV0200( CSMT, ISMT )
C-----
C  SIMPLIFIED MAPPING DATA PROCESSING ROUTINE
C-----
      CHARACTER  CSMT(2500)*1
      INTEGER*4  ISMT(25,25,4)
      DO 2100 IL1=1,25
        DO 2200 IL2=1,25
          ILAT = 60-(IL1-1)*5
          ILON = 80+(IL2-1)*5
          IL3 = (IL1-1)*100+(IL2-1)*4+1
          ILINE1 = ICHAR( CSMT( IL3 ) (1:1) )*256+ICHAR( CSMT( IL3+1 ) (1:1) )
          IPIXEL = ICHAR( CSMT( IL3+2 ) (1:1) )*256+ICHAR( CSMT( IL3+3 ) (1:1) )
          ISMT( IL2, IL1, 1 ) = ILAT
          ISMT( IL2, IL1, 2 ) = ILON
          ISMT( IL2, IL1, 3 ) = ILINE1
          ISMT( IL2, IL1, 4 ) = IPIXEL
        2200 CONTINUE
      2100 CONTINUE
  RETURN
END
SUBROUTINE SV0300( COBAT ,JSMT )
C-----
C  ORBIT AND ATTITUDE DATA PROCESSING ROUTINE
C-----
      COMMON /MMAP1/ MAP
      INTEGER*4  MAP(672,4)
      CHARACTER  COBAT*3200
      INTEGER*4  JSMT(25,25,4)
      REAL*4     R4DMY,RESLIN(4),RESELM(4),RLIC(4),RELMFC(4),SENSSU(4),
      .          VMIS(3),ELMIS(3,3),RLINE(4),RELMNT(4),RINF(8)
      REAL*8     R8DMY,DSPIN,DTIMS,ATIT(10,33),ORBT1(35,8),DSCT
C
      EQUIVALENCE ( MAP( 5,1 ),DTIMS ), ( MAP( 7,1 ),RESLIN(1) )
      EQUIVALENCE ( MAP(11,1),RESELM(1) ), ( MAP(15,1),RLIC(1) )

```

MTSAT HiRID Technical Information
Issue 3, 1 June 1999

```
EQUIVALENCE (MAP(19,1),RELMFC(1)),(MAP(27,1),SENSSU(1))  
EQUIVALENCE (MAP(31,1),RLINE(1)), (MAP(35,1),RELMNT(1))  
EQUIVALENCE (MAP(39,1),VMIS(1)), (MAP(42,1),ELMIS)  
EQUIVALENCE (MAP(131,1),DSPIN)  
EQUIVALENCE (MAP(13,3),ORBT1(1,1)),(MAP(13,2),ATIT(1,1))
```

C

```
DO 1000 I=1,4  
  DO 1100 J=1,672  
    MAP(J,I) = 0
```

1100 CONTINUE

1000 CONTINUE

C

```
CALL SV0100( 6, 8, COBAT( 1: 6), R4DMY , DTIMS )  
CALL SV0100( 4, 8, COBAT( 7: 10), RESLIN(1), R8DMY )  
CALL SV0100( 4, 8, COBAT( 11: 14), RESLIN(2), R8DMY )  
CALL SV0100( 4, 8, COBAT( 11: 14), RESLIN(3), R8DMY )  
CALL SV0100( 4, 8, COBAT( 11: 14), RESLIN(4), R8DMY )  
CALL SV0100( 4,10, COBAT( 15: 18), RESELM(1), R8DMY )  
CALL SV0100( 4,10, COBAT( 19: 22), RESELM(2), R8DMY )  
CALL SV0100( 4,10, COBAT( 19: 22), RESELM(3), R8DMY )  
CALL SV0100( 4,10, COBAT( 19: 22), RESELM(4), R8DMY )  
CALL SV0100( 4, 4, COBAT( 23: 26), RLIC(1) , R8DMY )  
CALL SV0100( 4, 4, COBAT( 27: 30), RLIC(2) , R8DMY )  
CALL SV0100( 4, 4, COBAT(111:114), RLIC(3) , R8DMY )  
CALL SV0100( 4, 4, COBAT(115:118), RLIC(4) , R8DMY )  
CALL SV0100( 4, 4, COBAT( 31: 34), RELMFC(1), R8DMY )  
CALL SV0100( 4, 4, COBAT( 35: 38), RELMFC(2), R8DMY )  
CALL SV0100( 4, 4, COBAT(119:122), RELMFC(3), R8DMY )  
CALL SV0100( 4, 4, COBAT(123:126), RELMFC(4), R8DMY )  
CALL SV0100( 4, 0, COBAT( 39: 42), SENSSU(1), R8DMY )  
CALL SV0100( 4, 0, COBAT( 43: 46), SENSSU(2), R8DMY )  
CALL SV0100( 4, 0, COBAT( 43: 46), SENSSU(3), R8DMY )  
CALL SV0100( 4, 0, COBAT( 43: 46), SENSSU(4), R8DMY )  
CALL SV0100( 4, 0, COBAT( 47: 50), RLINE(1) , R8DMY )  
CALL SV0100( 4, 0, COBAT( 51: 54), RLINE(2) , R8DMY )  
CALL SV0100( 4, 0, COBAT( 51: 54), RLINE(3) , R8DMY )  
CALL SV0100( 4, 0, COBAT( 51: 54), RLINE(4) , R8DMY )  
CALL SV0100( 4, 0, COBAT( 55: 58), RELMNT(1), R8DMY )  
CALL SV0100( 4, 0, COBAT( 59: 62), RELMNT(2), R8DMY )  
CALL SV0100( 4, 0, COBAT( 59: 62), RELMNT(3), R8DMY )  
CALL SV0100( 4, 0, COBAT( 59: 62), RELMNT(4), R8DMY )  
CALL SV0100( 4,10, COBAT( 63: 66), VMIS(1) , R8DMY )  
CALL SV0100( 4,10, COBAT( 67: 70), VMIS(2) , R8DMY )  
CALL SV0100( 4,10, COBAT( 71: 74), VMIS(3) , R8DMY )  
CALL SV0100( 4, 7, COBAT( 75: 78), ELMIS(1,1), R8DMY )  
CALL SV0100( 4,10, COBAT( 79: 82), ELMIS(2,1), R8DMY )  
CALL SV0100( 4,10, COBAT( 83: 86), ELMIS(3,1), R8DMY )  
CALL SV0100( 4,10, COBAT( 87: 90), ELMIS(1,2), R8DMY )  
CALL SV0100( 4, 7, COBAT( 91: 94), ELMIS(2,2), R8DMY )  
CALL SV0100( 4,10, COBAT( 95: 98), ELMIS(3,2), R8DMY )  
CALL SV0100( 4,10, COBAT( 99:102), ELMIS(1,3), R8DMY )  
CALL SV0100( 4,10, COBAT(103:106), ELMIS(2,3), R8DMY )  
CALL SV0100( 4, 7, COBAT(107:110), ELMIS(3,3), R8DMY )  
CALL SV0100( 6, 8, COBAT(241:246), R4DMY , DSPIN )
```

C

```
DO 2000 I=1,10  
  J = (I-1)*64+257-1  
  CALL SV0100(6, 8,COBAT( 1+J: 6+J),R4DMY,ATIT(1,I))  
  CALL SV0100(6, 8,COBAT(13+J:18+J),R4DMY,ATIT(3,I))  
  CALL SV0100(6,11,COBAT(19+J:24+J),R4DMY,ATIT(4,I))  
  CALL SV0100(6, 8,COBAT(25+J:30+J),R4DMY,ATIT(5,I))  
  CALL SV0100(6, 8,COBAT(31+J:36+J),R4DMY,ATIT(6,I))
```

2000 CONTINUE

C

```
DO 3000 I=1,8  
  J = (I-1)*256+897-1  
  CALL SV0100(6, 8,COBAT( 1+J: 6+J),R4DMY,ORBT1( 1,I))  
  CALL SV0100(6, 6,COBAT( 49+J: 54+J),R4DMY,ORBT1( 9,I))
```

MTSAT HiRID Technical Information
Issue 3, 1 June 1999

```

CALL SV0100(6, 6, COBAT( 55+J: 60+J), R4DMY, ORBT1(10, I))
CALL SV0100(6, 6, COBAT( 61+J: 66+J), R4DMY, ORBT1(11, I))
CALL SV0100(6, 8, COBAT( 85+J: 90+J), R4DMY, ORBT1(15, I))
CALL SV0100(6, 8, COBAT(103+J:108+J), R4DMY, ORBT1(18, I))
CALL SV0100(6, 8, COBAT(109+J:114+J), R4DMY, ORBT1(19, I))
CALL SV0100(6,12, COBAT(129+J:134+J), R4DMY, ORBT1(20, I))
CALL SV0100(6,14, COBAT(135+J:140+J), R4DMY, ORBT1(21, I))
CALL SV0100(6,14, COBAT(141+J:146+J), R4DMY, ORBT1(22, I))
CALL SV0100(6,14, COBAT(147+J:152+J), R4DMY, ORBT1(23, I))
CALL SV0100(6,12, COBAT(153+J:158+J), R4DMY, ORBT1(24, I))
CALL SV0100(6,16, COBAT(159+J:164+J), R4DMY, ORBT1(25, I))
CALL SV0100(6,12, COBAT(165+J:170+J), R4DMY, ORBT1(26, I))
CALL SV0100(6,16, COBAT(171+J:176+J), R4DMY, ORBT1(27, I))
CALL SV0100(6,12, COBAT(177+J:182+J), R4DMY, ORBT1(28, I))
3000 CONTINUE
C
DO 4100 IL1=1,25
DO 4200 IL2=1,25
RLAT = FLOAT( 60-(IL1-1)*5 )
RLON = FLOAT( 80+(IL2-1)*5 )
CALL MGIVSR(2, RPIX, RLIN, RLON, RLAT, 0.0, RINF, DSCT, IRTN)
JSMT(IL2, IL1, 1) = NINT( RLAT )
JSMT(IL2, IL1, 2) = NINT( RLON )
JSMT(IL2, IL1, 3) = NINT( RLIN )
JSMT(IL2, IL1, 4) = NINT( RPIX )
4200 CONTINUE
4100 CONTINUE
C
RETURN
END
SUBROUTINE MGIVSR( IMODE, RPIX, RLIN, RLON, RLAT, RHGT,
. RINF, DSCT, IRTN)
C
C*****
C*****
C*****
C*****
C
C THIS PROGRAM CONVERTS GEOGRAPHICAL CO-ORDINATES (LATITUDE, LONGITUDE,
C HEIGHT) TO VISSR IMAGE CO-ORDINATES (LINE, PIXEL) AND VICE VERSA.
C
C THIS PROGRAM IS PROVIDED BY THE METEOROLOGICAL SATELLITE CENTER OF
C THE JAPAN METEOROLOGICAL AGENCY TO USERS OF GMS DATA.
C
C
C MSC TECH. NOTE NO.23
C JMA/MSC 1991
C
C*****
C*****
C*****
C*****
C
C
C I/O TYPE
C IMODE I I*4 CONVERSION MODE & IMAGE KIND
C IMAGE KIND
C GMS-4 GMS-5 MTSAT
C 1,-1 VIS VIS VIS
C 2,-2 IR IR1 IR1, IR4
C 3,-3 -- IR2 IR2
C 4,-4 -- WV WV
C CONVERSION MODE
C 1 TO 4 (LAT, LON, HGT)=>(LINE, PIXEL)
C -1 TO -4 (LAT, LON )<=(LINE, PIXEL)
C RPIX I/O R*4 PIXEL OF POINT
C RLIN I/O R*4 LINE OF POINT
C RLON I/O R*4 LONGITUDE OF POINT (DEGREES, EAST:+, WEST:-)
C RLAT I/O R*4 LATITUDE OF POINT (DEGREES, NORTH:+, SOUTH:-)

```

MTSAT HiRID Technical Information
Issue 3, 1 June 1999

```

C   RHGT      I   R*4   HEIGHT OF POINT (METER)
C   RINF(8)   O   R*4   (1) SATELLITE ZENITH DISTANCE (DEGREES)
C                                     (2) SATELLITE AZIMUTH ANGLE (DEGREES)
C                                     (3) SUN ZENITH DISTANCE (DEGREES)
C                                     (4) SUN AZIMUTH ANGLE (DEGREES)
C                                     (5) SATELLITE-SUN DIPARTURE ANGLE (DEGREES)
C                                     (6) SATELLITE DISTANCE (METER)
C                                     (7) SUN DISTANCE (KILO-METER)
C                                     (8) SUN GRINT ANGLE (DEGREES)
C   DSCT      O   R*8   SCAN TIME (MJD)
C   IRTN      O   I*4   RETURN CODE (0=O.K.)
C
C!!!!!!!!!!!!!!!!!!!!!!!!!!!!!!!!!!!!!!!!!!!!!!!!!!!!!!!!!!!!!!!!!!!!!!!!!!!!
C
C   COMMON /MMAP1/MAP(672,4)
C
C   1. COORDINATE TRANSFORMATION PARAMETERS SEGMENT
C                                     MAP(1,1)-MAP(672,1)
C   2. ATTITUDE PREDICTION DATA SEGMENT   MAP(1,2)-MAP(672,2)
C   3. ORBIT PREDICTION DATA 1 SEGMENT     MAP(1,3)-MAP(672,3)
C   4. ORBIT PREDICTION DATA 2 SEGMENT     MAP(1,4)-MAP(672,4)
C*****
C
C!!!!!!!!!!!!!!!!!!!!!!!!!!!! DEFINITION !!!!!!!!!!!!!!!!!!!!!!!!!!!!!!!!!!!!!
C   COMMON /MMAP1/MAP
C
C   REAL*4      RPIX,RLIN,RLON,RLAT,RHGT,RINF(8)
C   INTEGER*4   MAP(672,4),IRTN
C
C   REAL*4      EPS,RI0,RI,RJ,RSTEP,RSAMP,RFCL,RFCP,SENS,RFTL,RFTP
C   REAL*4      RESLIN(4),RESELM(4),RLIC(4),RELMFC(4),SENSSU(4),
C   .           VMIS(3),ELMIS(3,3),RLINE(4),RELMNT(4)
C   REAL*8      BC,BETA,BS,CDR,CRD,DD,DDA,ddb,DDC,DEF,DK,DK1,DK2,
C   .           DLAT,DLON,DPAI,DSPIN,DTIMS,EA,EE,EF,EN,HPAI,PC,PI,PS,
C   .           QC,QS,RTIM,TF,TL,TP,
C   .           SAT(3),SL(3),SLV(3),SP(3),SS(3),STN1(3),STN2(3),
C   .           SX(3),SY(3),SW1(3),SW2(3),SW3(3)
C   REAL*8      DSCT,DSATZ,DSATA,DSUNZ,DSUNA,DSSDA,DSATD,SUNM,SDIS,
C   .           DLATN,DLONN,STN3(3),DSUNG
C
C!!!!!!!!!!!!!!!!!!!!!!!!!!!! EQUIVALENCE !!!!!!!!!!!!!!!!!!!!!!!!!!!!!!!!!!!!!
C   EQUIVALENCE (MAP( 5,1),DTIMS),      (MAP( 7,1),RESLIN(1))
C   EQUIVALENCE (MAP(11,1),RESELM(1)), (MAP(15,1),RLIC(1))
C   EQUIVALENCE (MAP(19,1),RELMFC(1)), (MAP(27,1),SENSSU(1))
C   EQUIVALENCE (MAP(31,1),RLINE(1)),   (MAP(35,1),RELMNT(1))
C   EQUIVALENCE (MAP(39,1),VMIS(1)),   (MAP(42,1),ELMIS)
C   EQUIVALENCE (MAP(131,1),DSPIN)
C
C*****
C
C   PI      = 3.141592653D0
C   CDR     = PI/180.D0
C   CRD     = 180.D0/PI
C   HPAI    = PI/2.D0
C   DPAI    = PI*2.D0
C   EA      = 6378136.D0
C   EF      = 1.D0/298.257D0
C   EPS     = 1.0
C!!!!!!!!!!!!!!!!!!!!!!!!!!!! PARAMETER CHECK !!!!!!!!!!!!!!!!!!!!!!!!!!!!!!!!!!!!!
C   IRTN    = 0
C   IF(ABS(IMODE).GT.4) IRTN=1
C   IF(ABS(RLAT).GT.90. .AND. IMODE.GT.0) IRTN=2
C   IF(IRTN.NE.0) RETURN
C!!!!!!!!!!!!!!!!!!!!!!!!!!!! VISSR FRAME INFORMATION SET !!!!!!!!!!!!!!!!!!!!!!!!!!!!!
C   LMODE   = ABS(IMODE)

```

MTSAT HiRID Technical Information
Issue 3, 1 June 1999

```

RSTEP  = RESLIN(LMODE)
RSAMP  = RESELM(LMODE)
RFCL   = RLIC(LMODE)
RFCL   = RELMFC(LMODE)
SENS   = SENSSU(LMODE)
RFTL   = RLINE(LMODE)+0.5
RFTP   = RELMNT(LMODE)+0.5
C!!!!!!!!!!!!!!!!!!!! TRANSFORMATION (GEOGRAPHICAL=>VISSR) !!!!!!!!!!!!!!!!!!!!!
IF( IMODE.GT.0 .AND. IMODE.LT.5 ) THEN
  DLAT  = DBLE(RLAT)*CDR
  DLON  = DBLE(RLON)*CDR
  EE     = 2.D0*EF-EF*EF
  EN     = EA/DSQRT(1.D0-EE*DSIN(DLAT)*DSIN(DLAT))
  STN1(1) = (EN+DBLE(RHGT))*DCOS(DLAT)*DCOS(DLON)
  STN1(2) = (EN+DBLE(RHGT))*DCOS(DLAT)*DSIN(DLON)
  STN1(3) = (EN*(1.D0-EE)+DBLE(RHGT))*DSIN(DLAT)
C
  RIO   = RFCL-ATAN(SIN(SNGL(DLAT))/(6.610689-COS(SNGL(DLAT))))
        /RSTEP
  RTIM  = DTIMS+DBLE(RIO/SENS/1440.)/DSPIN
C
100  CONTINUE
CALL  MGI100(RTIM,CDR,SAT,SP,SS,BETA)
C-----
CALL  MGI220(SP,SS,SW1)
CALL  MGI220(SW1,SP,SW2)
BC    = DCOS(BETA)
BS    = DSIN(BETA)
SW3(1) = SW1(1)*BS+SW2(1)*BC
SW3(2) = SW1(2)*BS+SW2(2)*BC
SW3(3) = SW1(3)*BS+SW2(3)*BC
CALL  MGI200(SW3,SX)
CALL  MGI220(SP,SX,SY)
SLV(1) = STN1(1)-SAT(1)
SLV(2) = STN1(2)-SAT(2)
SLV(3) = STN1(3)-SAT(3)
CALL  MGI200(SLV,SL)
CALL  MGI210(SP,SL,SW2)
CALL  MGI210(SY,SW2,SW3)
CALL  MGI230(SY,SW2,TP)
TF    = SP(1)*SW3(1)+SP(2)*SW3(2)+SP(3)*SW3(3)
IF(TF.LT.0.D0) TP=-TP
CALL  MGI230(SP,SL,TL)
C
RI    = SNGL(HPAI-TL)/RSTEP+RFCL-VMIS(2)/RSTEP
RJ    = SNGL(TP)/RSAMP+RFCL
        +VMIS(3)/RSAMP-SNGL(HPAI-TL)*TAN(VMIS(1))/RSAMP
C
IF(ABS(RI-RI0).GE.EPS) THEN
  RTIM = DBLE(AINT((RI-1.)/SENS)+RJ*RSAMP/SNGL(DPAI))/
        (DSPIN*1440.D0)+DTIMS
  RIO  = RI
  GO TO 100
ENDIF
RLIN  = RI
RPIX  = RJ
DSCT  = RTIM
IF(RLIN.LT.0 .OR. RLIN.GT.RFTL) IRTN=4
IF(RPIX.LT.0 .OR. RPIX.GT.RFTP) IRTN=5
C
C!!!!!!!!!!!!!!!!!!!! TRANSFORMATION (VISSR=>GEOGRAPHICAL) !!!!!!!!!!!!!!!!!!!!!
ELSEIF(IMODE.LT.0 .AND. IMODE.GT.-5) THEN
C
  RTIM  = DBLE(AINT((RLIN-1.)/SENS)+RPIX*RSAMP/SNGL(DPAI))/
        (DSPIN*1440.D0)+DTIMS
CALL  MGI100(RTIM,CDR,SAT,SP,SS,BETA)
CALL  MGI220(SP,SS,SW1)
CALL  MGI220(SW1,SP,SW2)

```

MTSAT HiRID Technical Information
Issue 3, 1 June 1999

```

BC      = DCOS(BETA)
BS      = DSIN(BETA)
SW3(1) = SW1(1)*BS+SW2(1)*BC
SW3(2) = SW1(2)*BS+SW2(2)*BC
SW3(3) = SW1(3)*BS+SW2(3)*BC
CALL   MGI200(SW3,SX)
CALL   MGI220(SP,SX,SY)
PC      = DCOS(DBLE(RSTEP*(RLIN-RFCL)))
PS      = DSIN(DBLE(RSTEP*(RLIN-RFCL)))
QC      = DCOS(DBLE(RSAMP*(RPIX-RFCP)))
QS      = DSIN(DBLE(RSAMP*(RPIX-RFCP)))
SW1(1) = DBLE(ELMIS(1,1))*PC+DBLE(ELMIS(1,3))*PS
SW1(2) = DBLE(ELMIS(2,1))*PC+DBLE(ELMIS(2,3))*PS
SW1(3) = DBLE(ELMIS(3,1))*PC+DBLE(ELMIS(3,3))*PS
SW2(1) = QC*SW1(1)-QS*SW1(2)
SW2(2) = QS*SW1(1)+QC*SW1(2)
SW2(3) = SW1(3)
SW3(1) = SX(1)*SW2(1)+SY(1)*SW2(2)+SP(1)*SW2(3)
SW3(2) = SX(2)*SW2(1)+SY(2)*SW2(2)+SP(2)*SW2(3)
SW3(3) = SX(3)*SW2(1)+SY(3)*SW2(2)+SP(3)*SW2(3)
CALL   MGI200(SW3,SL)
DEF     = (1.D0-EF)*(1.D0-EF)
DDA     = DEF*(SL(1)*SL(1)+SL(2)*SL(2)+SL(3)*SL(3))
DDB     = DEF*(SAT(1)*SL(1)+SAT(2)*SL(2)+SAT(3)*SL(3))
DDC     = DEF*(SAT(1)*SAT(1)+SAT(2)*SAT(2)-EA*EA)+SAT(3)*SAT(3)
DD      = DDB*DDB-DDA*DDC
IF(DD.GE.0.D0 .AND. DDA.NE.0.D0) THEN
  DK1    = (-DDB+DSQRT(DD))/DDA
  DK2    = (-DDB-DSQRT(DD))/DDA
ELSE
  IRTN   = 6
  GO TO  9000
ENDIF
IF(DABS(DK1).LE.DABS(DK2)) THEN
  DK     = DK1
ELSE
  DK     = DK2
ENDIF
STN1(1) = SAT(1)+DK*SL(1)
STN1(2) = SAT(2)+DK*SL(2)
STN1(3) = SAT(3)+DK*SL(3)
DLAT    = DATAN(STN1(3)/(DEF*DSQRT(STN1(1)*STN1(1)+
  STN1(2)*STN1(2)))
IF(STN1(1).NE.0.D0) THEN
  DLON   = DATAN(STN1(2)/STN1(1))
  IF(STN1(1).LT.0.D0 .AND. STN1(2).GE.0.D0) DLON=DLON+PI
  IF(STN1(1).LT.0.D0 .AND. STN1(2).LT.0.D0) DLON=DLON-PI
ELSE
  IF(STN1(2).GT.0.D0) THEN
    DLON=HPAI
  ELSE
    DLON=-HPAI
  ENDIF
ENDIF
ENDIF
RLAT    = SNGL(DLAT*CRD)
RLON    = SNGL(DLON*CRD)
DSCT    = RTIM
ENDIF
C
C!!!!!!!!!!!!!!!!!!!! TRANSFORMATION (ZENITH/AZIMUTH) !!!!!!!!!!!!!!!!!!!!!
STN2(1) = DCOS(DLAT)*DCOS(DLON)
STN2(2) = DCOS(DLAT)*DSIN(DLON)
STN2(3) = DSIN(DLAT)
SLV(1)  = SAT(1)-STN1(1)
SLV(2)  = SAT(2)-STN1(2)
SLV(3)  = SAT(3)-STN1(3)
CALL   MGI200(SLV,SL)
C

```

MTSAT HiRID Technical Information
Issue 3, 1 June 1999

```

CALL MGI230(STN2,SL,DSATZ)
IF(DSATZ.GT.HPAI) IRTN = 7
C
SUNM      = 315.253D0+0.985600D0*RTIM
SUNM      = DMOD(SUNM,360.D0)*CDR
SDIS      = (1.00014D0-0.01672D0*DCOS(SUNM)-0.00014*DCOS(2.D0*
.          SUNM))*1.49597870D8
C
IF(DLAT.GE.0.D0) THEN
  DLATN    = HPAI-DLAT
  DLONN    = DLON-PI
  IF(DLONN.LE.-PI) DLONN=DLONN+DPAI
ELSE
  DLATN    = HPAI+DLAT
  DLONN    = DLON
ENDIF
STN3(1)   = DCOS(DLATN)*DCOS(DLONN)
STN3(2)   = DCOS(DLATN)*DSIN(DLONN)
STN3(3)   = DSIN(DLATN)
SW1(1)    = SLV(1)+SS(1)*SDIS*1.D3
SW1(2)    = SLV(2)+SS(2)*SDIS*1.D3
SW1(3)    = SLV(3)+SS(3)*SDIS*1.D3
CALL MGI200(SW1,SW2)
CALL MGI230(STN2,SW2,DSUNZ)
CALL MGI230(SL,SW2,DSSDA)
CALL MGI240(SL,STN2,STN3,DPAI,DSATA)
CALL MGI240(SW2,STN2,STN3,DPAI,DSUNA)
DSATD     = DSQRT(SLV(1)*SLV(1)+SLV(2)*SLV(2)+SLV(3)*SLV(3))
C
C
CALL MGI200(STN1,SL)
CALL MGI230(SW2,SL,DSUNG)
CALL MGI220(SL,SW2,SW3)
CALL MGI220(SW3,SL,SW1)
WKCOS=DCOS(DSUNG)
WKSIN=DSIN(DSUNG)
SW2(1)=WKCOS*SL(1)-WKSIN*SW1(1)
SW2(2)=WKCOS*SL(2)-WKSIN*SW1(2)
SW2(3)=WKCOS*SL(3)-WKSIN*SW1(3)
CALL MGI230(SW2,SLV,DSUNG)
C
RINF(6)   = SNGL(DSATD)
RINF(7)   = SNGL(SDIS)
RINF(1)   = SNGL(DSATZ*CRD)
RINF(2)   = SNGL(DSATA*CRD)
RINF(3)   = SNGL(DSUNZ*CRD)
RINF(4)   = SNGL(DSUNA*CRD)
RINF(5)   = SNGL(DSSDA*CRD)
RINF(8)   = SNGL(DSUNG*CRD)
C!!!!!!!!!!!!!!!!!!!!!! STOP/END !!!!!!!!!!!!!!!!!!!!!!!!!!!!!!!!!!!!!!!!!!!!!!!
9000 CONTINUE
RETURN
END
SUBROUTINE MGI100(RTIM,CDR,SAT,SP,SS,BETA)
COMMON /MMAP1/MAP
REAL*8    ATTALP,ATTDEL,BETA,CDR,DELT,RTIM,SITAGT,SUNALP,SUNDEL,
.          WKCOS,WKSIN
REAL*8    ATIT(10,10),ATT1(3),ATT2(3),ATT3(3),NPA(3,3),
.          ORBT1(35,8),SAT(3),SP(3),SS(3)
INTEGER*4  MAP(672,4)
C
EQUIVALENCE (MAP(13,3),ORBT1(1,1))
EQUIVALENCE (MAP(13,2),ATIT(1,1))
C
DO 1000 I=1,7
  IF(RTIM.GE.ORBT1(1,I).AND.RTIM.LT.ORBT1(1,I+1)) THEN
    CALL MGI110
.      (I,RTIM,CDR,ORBT1,ORBT2,SAT,SITAGT,SUNALP,SUNDEL,NPA)

```

MTSAT HiRID Technical Information
Issue 3, 1 June 1999

```

        GO TO 1200
    ENDIF
1000 CONTINUE
1200 CONTINUE
C
DO 3000 I=1,33-1
    IF(RTIM.GE.ATIT(1,I) .AND. RTIM.LT.ATIT(1,I+1)) THEN
        DELT = (RTIM-ATIT(1,I))/(ATIT(1,I+1)-ATIT(1,I))
        ATTALP = ATIT(3,I)+(ATIT(3,I+1)-ATIT(3,I))*DELT
        ATTDDEL = ATIT(4,I)+(ATIT(4,I+1)-ATIT(4,I))*DELT
        BETA = ATIT(5,I)+(ATIT(5,I+1)-ATIT(5,I))*DELT
        IF( (ATIT(5,I+1)-ATIT(5,I)).GT.0.D0 )
            BETA = ATIT(5,I)+(ATIT(5,I+1)-ATIT(5,I)-360.D0*CDR)*DELT
        GO TO 3001
    ENDIF
3000 CONTINUE
3001 CONTINUE
C
WKCOS = DCOS(ATTDEL)
ATT1(1) = DSIN(ATTDEL)
ATT1(2) = WKCOS *(-DSIN(ATTALP))
ATT1(3) = WKCOS *DCOS(ATTALP)
ATT2(1) = NPA(1,1)*ATT1(1)+NPA(1,2)*ATT1(2)+NPA(1,3)*ATT1(3)
ATT2(2) = NPA(2,1)*ATT1(1)+NPA(2,2)*ATT1(2)+NPA(2,3)*ATT1(3)
ATT2(3) = NPA(3,1)*ATT1(1)+NPA(3,2)*ATT1(2)+NPA(3,3)*ATT1(3)
WKSIN = DSIN(SITAGT)
WKCOS = DCOS(SITAGT)
ATT3(1) = WKCOS*ATT2(1)+WKSIN*ATT2(2)
ATT3(2) =-WKSIN*ATT2(1)+WKCOS*ATT2(2)
ATT3(3) = ATT2(3)
CALL MGI200(ATT3,SP)
C
WKCOS = DCOS(SUNDEL)
SS(1) = WKCOS *DCOS(SUNALP)
SS(2) = WKCOS *DSIN(SUNALP)
SS(3) = DSIN(SUNDEL)
C
RETURN
END
SUBROUTINE MGI110
    ( I,RTIM,CDR,ORBTA,ORBTB,SAT,SITAGT,SUNALP,SUNDEL,NPA)
REAL*8 CDR,SAT(3),RTIM,ORBTA(35,8),ORBTB(35,8)
REAL*8 SITAGT,SUNDEL,SUNALP,NPA(3,3),DELT
INTEGER*4 I
IF(I.NE.8) THEN
    DELT=(RTIM-ORBTA(1,I))/(ORBTA(1,I+1)-ORBTA(1,I))
    SAT(1) = ORBTA(9,I)+(ORBTA(9,I+1)-ORBTA(9,I))*DELT
    SAT(2) = ORBTA(10,I)+(ORBTA(10,I+1)-ORBTA(10,I))*DELT
    SAT(3) = ORBTA(11,I)+(ORBTA(11,I+1)-ORBTA(11,I))*DELT
    SITAGT = (ORBTA(15,I)+(ORBTA(15,I+1)-ORBTA(15,I))*DELT)*CDR
    IF( (ORBTA(15,I+1)-ORBTA(15,I)).LT.0.D0 )
        SITAGT = (ORBTA(15,I)+(ORBTA(15,I+1)-ORBTA(15,I)+360.D0)
            *DELT)*CDR
    SUNALP = (ORBTA(18,I)+(ORBTA(18,I+1)-ORBTA(18,I))*DELT)*CDR
    IF( (ORBTA(18,I+1)-ORBTA(18,I)).GT.0.D0 )
        SUNALP = (ORBTA(18,I)+(ORBTA(18,I+1)-ORBTA(18,I)-360.D0)
            *DELT)*CDR
    SUNDEL = (ORBTA(19,I)+(ORBTA(19,I+1)-ORBTA(19,I))*DELT)*CDR
    NPA(1,1) = ORBTA(20,I)
    NPA(2,1) = ORBTA(21,I)
    NPA(3,1) = ORBTA(22,I)
    NPA(1,2) = ORBTA(23,I)
    NPA(2,2) = ORBTA(24,I)
    NPA(3,2) = ORBTA(25,I)
    NPA(1,3) = ORBTA(26,I)
    NPA(2,3) = ORBTA(27,I)
    NPA(3,3) = ORBTA(28,I)
ENDIF

```

```
RETURN
END
SUBROUTINE MGI200(VECT,VECTU)
REAL*8  VECT(3),VECTU(3),RV1,RV2
RV1=VECT(1)*VECT(1)+VECT(2)*VECT(2)+VECT(3)*VECT(3)
IF(RV1.EQ.0.D0) RETURN
RV2=DSQRT(RV1)
VECTU(1)=VECT(1)/RV2
VECTU(2)=VECT(2)/RV2
VECTU(3)=VECT(3)/RV2
RETURN
END
```

C

```
SUBROUTINE MGI210(VA,VB,VC)
REAL*8  VA(3),VB(3),VC(3)
VC(1)= VA(2)*VB(3)-VA(3)*VB(2)
VC(2)= VA(3)*VB(1)-VA(1)*VB(3)
VC(3)= VA(1)*VB(2)-VA(2)*VB(1)
RETURN
END
SUBROUTINE MGI220(VA,VB,VD)
REAL*8  VA(3),VB(3),VC(3),VD(3)
VC(1)= VA(2)*VB(3)-VA(3)*VB(2)
VC(2)= VA(3)*VB(1)-VA(1)*VB(3)
VC(3)= VA(1)*VB(2)-VA(2)*VB(1)
CALL MGI200(VC,VD)
RETURN
END
SUBROUTINE MGI230(VA,VB,ASITA)
REAL*8  VA(3),VB(3),ASITA,AS1,AS2
AS1= VA(1)*VB(1)+VA(2)*VB(2)+VA(3)*VB(3)
AS2=(VA(1)*VA(1)+VA(2)*VA(2)+VA(3)*VA(3))*
      (VB(1)*VB(1)+VB(2)*VB(2)+VB(3)*VB(3))
IF(AS2.EQ.0.D0) RETURN
ASITA=DACOS(AS1/DSQRT(AS2))
RETURN
END
SUBROUTINE MGI240(VA,VH,VN,DPAI,AZI)
REAL*8  VA(3),VH(3),VN(3),VB(3),VC(3),VD(3),DPAI,AZI,DNAI
CALL MGI220(VN,VH,VB)
CALL MGI220(VA,VH,VC)
CALL MGI230(VB,VC,AZI)
CALL MGI220(VB,VC,VD)
DNAI = VD(1)*VH(1)+VD(2)*VH(2)+VD(3)*VH(3)
IF(DNAI.GT.0.D0) AZI=DPAI-AZI
RETURN
END
```

Copyright ©1998 by the Meteorological Satellite Centre.

APPENDIX C

Processing of expanded infrared data with a sample program

The figures and program in this appendix show the method to extract 10-bit data from upper 8-bit and lower 2 bit data IR1, IR2 and IR3 and 10-bit data of IR4.

1. Method to combine IR1-3 data

First, upper 8-bit data is shifted to the left side in order to express data of IR1-3 as 10-bit data in the same area.

Second, lower 2-bit data is set to the 2 bits area of the right side.

Finally, it is computable as 10-bit data combined in **Figure C-1**.

2. Method to handle IR4 data

IR4 data are stored as 10-bit values. As data have to be processed in 8-bit (1 byte) data in a computer, 10-bit data are converted into 16-bit (2 byte) integer shown in **Figure C-2**.

Appendix C - Sample program for expanded IR data handling method

```
/* Sample program ( C Language )
** IR4 10 bits data handling method
** IR1-3 divided data ( upper 8 data and lower 2 bits data ) combination method
*/
int convert_8bit_10bit ( hirid_raw , channel , data_10bit )
    /* Return code Normal: 0 , Abnormal: -1 */
char hirid_raw [ ]; /* Input HiRID raw data of 1 line : 49500 bytes */
int channel; /* Input channel IR1=1, IR2=2, IR3=3, IR4=4 */
short int data_10bit[ ]; /*Output 10 bits data (2291pixels * 2bytes)*/
{
long int pixelno; /* position of pixel */
long int ir4_start; /* (start bit position of IR4 data area)-1 */
long int upper_start; /* start bit position of upper 8 bits data area */
long int lower_start; /* start bit position of lower 2 bits data area */
long int start_byt; /* start byte position of each pixel in lower 2 bits data*/
long int start_bit; /* start bit position of each pixel in lower 2 bits data(0-7) */
long int end_byt; /* end byte position of each pixel in lower 2 bits data*/
long int end_bit; /* end bit position of each pixel in lower 2 bits data(0-7)*/
unsigned char dummy1,dummy2;
if (channel >4 || channel < 0 ) return (-1);
/* IR4 10 bits data handling program */
if (channel==4) {
    ir4_start = 349858; /* ( first bit of IR4 ) - 1 */
    for (pixelno = 0; pixelno < 2552; pixelno++){
        dummy1 = 0;
        dummy2 = 0;
        data_10bit[pixelno] = 0;
        start_byt = (int)(ir4_start+pixelno*10)/8+1;
        start_bit = (ir4_start+pixelno*10+8)-start_byt*8;
        end_byt = (int)(ir4_start+pixelno*10+10-1)/8+1;
        end_bit = ((ir4_start+pixelno*10+10+8)-end_byt*8);
        dummy1 = hirid_raw[start_byt];
        dummy2 = hirid_raw[end_byt];
        dummy1 <<= start_bit;
        dummy2 >>= (8-end_bit);
        data_10bit[pixelno] = dummy1*4 + dummy2;
    }
    return (0);
}
/* IR1-3 divided data (upper 8 bits data and lower 2 bits data) combination program */
if (channel == 1 || channel == 2 || channel == 3) {
    upper_start = 40408 + (channel-1)*20408;
    lower_start = 329872 + (channel-1)*6662;
    for (pixelno = 0; pixelno <2552; pixelno++) {
        dummy1 = 0;
        dummy2 = 0;
        data_10bit[pixelno] = 0;
        end_byt = (int)(lower_start+pixelno*2)/8+1;
        end_bit = (lower_start+pixelno*2+8)-end_byt*8;
        dummy1= hirid_raw[upper_start/8+pixelno+1];
        dummy2 = hirid_raw[end_byt];
        dummy2 <<= end_bit;
        dummy2 >>= 6;
        data_10bit[pixelno] = dummy1*4 + dummy2;
    }
    return (0);
}
}
```

1 line data format of HiRID

Offset (bits)	1	20001	40409	60817	81225	101633	158693	215753	272813	329873	336535	343197	349859	374849
Size (bits)	20000	20408	20408	20408	20408	57060	57060	57060	57060	6662	6662	6662	24990	21152
Contents	SYNC Code	Documentation Sector	IR 1 Sector	IR 2 Sector	IR 3 Sector	VIS 1 Sector	VIS 2 Sector	VIS 3 Sector	VIS 4 Sector	IR 1 Sector	IR 2 Sector	IR 3 Sector	IR 4 Sector	Dummy Data
			Upper 8 bits			6 bits				lower 2 bits			10 bits	

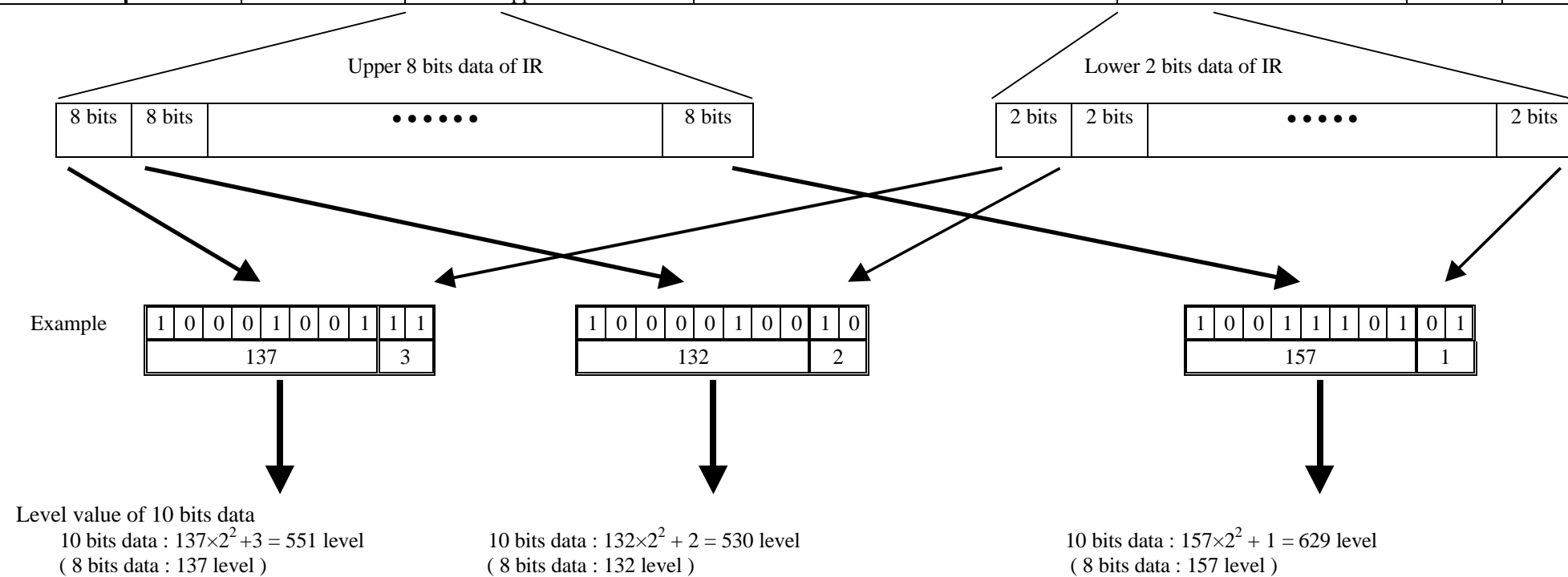

Figure C-1 Combined method for IR 1 - 3 data

Appendix C

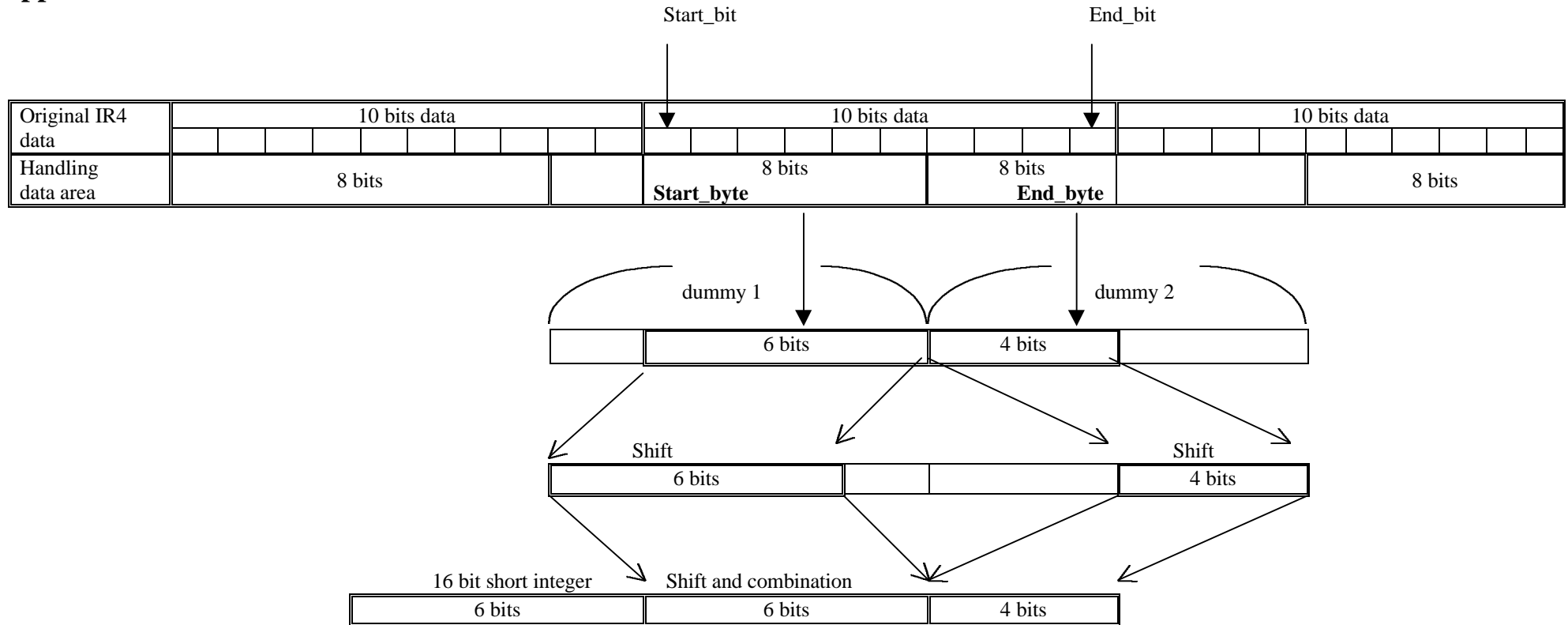

Figure C-2 Handling method for IR 4 data